

INVESTIGATION OPTIMISE PARAMETER OF UPPER CONTROL ARM FOR MINING BREAKER

Mayur S.Aware¹, W.S.Rathod²

¹Student (Mechanical Machine Design Engineering), Department of Mechanical Engineering, Veermata Jijabai Technological Institute, Mumbai, Maharashtra, India

²Assistant Professor in Mechanical Engineering, Department of Mechanical Engineering, Veermata Jijabai Technological Institute, Mumbai, Maharashtra, India

Abstract

Suspension system of automobile is always responsible for safety and driving comfort as the suspension carries the entire vehicle body and transmits all forces between road and body. Suspension system absorbs the vibrations due to rough terrains or road disturbances. Suspension system also provides stability under different conditions like accelerating, uneven road, cornering, braking, loading and unloading. For the vehicles of mining there is no such a suspension system exist as they stands at single point very long, to provide suspension system for the portable mining Breakers as lots of fatigue to human worker working with it. Control arm is important part of suspension system as it joints steering knuckle to vehicle frame. In automotive industry structure optimization techniques was used for light weight and performance improvement of modern new cars. However, static load conditions could not represent all the various situations of automobile parts which subjected to complex loads those varying with time, especially in case of crusher and for lower control arm of front suspension. This paper deals with transient structural analysis of the upper control arm of double wishbone suspension and modal analysis was carried out using ANSYS software for the mining Breaker. Optimization of upper control arm was carried out by selecting better material for weight reduction and better strength. Testing was carried out on Universal testing machine to validate analysis results.

Keywords: - Double wishbone suspension, mining, Breaker, Modal analysis, Steering knuckle, Transient structural analysis, ANSYS software, Universal testing machine

1. INTRODUCTION

Control arm is one of the most important part of any suspension system. It is made from the materials like steel, iron or aluminum. Arm is vital part for each vehicle on the road. Vehicle can results in annoying vibrations and undesirable driving irregularities that could sometimes cause to road accidents like collision with another vehicle or obstacle on road if there is no suspension arm. Suspension arm is fitted in different types of suspensions such as wishbone or double wishbone, Macpherson strut suspension. In Macpherson strut system maximum load is transferred tire to ball joint and in double wishbone maximum load is transferred from upper to lower arm which responsible for failure and twisting of lower arm at ball joint locations as well as control arm because of impact load. As in case of mining stone breakers, heavy working equipments are install at front side so maximum load can be transfer at front side of crusher ,but as of now there is no such suspension system in Breakers there is huge challenge to transfer heavy shock and load to the ground so to develop and changes in existing design of control arm use in a automotive suspension it is mandatory to focus on stress and deformation study of upper control arm. For transient structural analysis, modal analysis, optimization of upper control arm finite element approach is used.

2. LITERATURE REVIEW

The different work method to be carried out on control arm of system in recent years. Jagwinder Singh et al. [1] works on —Static Structural Analysis of Suspension Arm Using Finite Element Method. In this work the static structural analysis was done to find out the stress, deformation and safety factor of component and optimization approach is carried out to increase the structural strength of the component. Gurunath Biradar et al. [2] works on —Life Estimation Of Double Wishbone Suspension System of Passenger Car. In this thesis focus was on the modal analysis and statically analysis of upper arm, lower arm and steering knuckle. Fatigue analysis of existing double wishbone suspension system and modify the design using software's namely Unigraphics, Hypermesh, Optistruct and nCODE. A. Rutci [3] works on —Failure Analysis of a Lower Wishbone. Paper describes failure analysis of a lower wishbone in a light commercial vehicle has done which involved in service loading. To investigate reason of the failure, finite element analysis is done to evaluate stress distribution and reliability of wishbone. Furthermore, the metallographic and hardness evaluation were done on weld seam of the failed part. Finite Element Analysis and metallographic examination results showed that fatigue failure was occurred from highly stressed region in weld seam. Jong-kyu Kim et al. [4] paper

describes shape of upper control arm was determined by applying the optimization technology. Study considers the static strength of arm in the optimization process. In this study, the kriging interpolation method is acquired to obtain the minimum weight satisfying the static strength constraint. The real experiments on 1/4 car is conducted to validate the FEM analysis. At last, the correlation of each case about durability life is obtained. B. Sai Rahul et al. [5] paper shows works that „Fatigue Life Analysis of Upper Arm of Wishbone Suspension System“. In this characterization of the dynamic behavior and investigation of fatigue life of upper suspension arm is done. This study estimate the fatigue life of control arm. The results, thus obtained, can significantly reduce the cost and times to market improve product reliability. Prof. A. M. Patil et al. [6]. This paper shows the stress strain analysis study of lower wishbone arm to improve and modify the existing design. The result obtained using finite element analysis approach. Lihui Zhao et al. [7] works on —Dynamic Structure Optimization Design of Lower Control Arm Based on ESL. Lower control arm dynamic optimization was performed by incorporating traditional static load optimization techniques and multi-body dynamics by Equivalent Static Load (ESL) in this paper and the best draw-bead distribution of the stamped lower control arm was acquired. An optimized and existing result by comparison shows that the strength and stiffness was increased significantly while the mass was almost unchanged. N.A. Kadhim et al. [8] Fatigue life of lower suspension arm has been studied under different amplitude loadings. To obtain the material monotonic properties, tensile test has been carried out and to specify the material mechanical properties of the used material, a fatigue test under constant amplitude loading has been carried out using the ASTM standard specimens. Then, the results used in the finite element software to predict fatigue life has been evaluated later to show the accuracy and efficiency of the numerical models which they are appreciated. V.V. Jagirdar et al. [9] paper describes Wishbone structure for double wishbone front-independent suspension for a military truck. A double wishbone, double coil spring with twin damper configuration was employed for military truck application. MBD Analysis was done using ADAMS software. For the front axle of the vehicle double wishbone independent suspension has been designed. Y. Nadot et al. [10] an experimental device has been developed to study fatigue phenomena for nodular cast iron automotive suspension arms. A methodology is proposed to define the maximum defect size allowable in a casting component. It correlates the empirical method proposed by Murakami to determine the evolution of the fatigue limit with defect size and a multi axial endurance criterion based on the Dang Van model. Validation of the proposed approach gives encouraging results for surface defects and constant amplitude proportional loading.

3. PROBLEM DEFINITION

3.1 Problem Statement

In suspension system control arm is vital component. As the vehicle goes through bumps, speed breaker etc. some kinds of forces are to be transmitted from car wheels which get transferred to control arm via ball joint assembly to wheel. At constructional and Crushing site there is no such suspension system provided for the equipment so to aim is to provide suspension system for Breaker. General vehicle Control arms can bend or break when driving over large potholes, bumps while brushing can also wear out. Sometimes due to combination of forces like pitching, rolling, acceleration breakdown occurs due to large stress.

Problem statement: —To optimize and design the upper control arm of suspension system for portable mining Breakers with modeling and transient structural analysis of arm based on material. Modal analysis is done in addition. Further optimize arm validated by experimentation.

3.2 Objective

- Investigate stress and deformation of Existing Upper Control arm used in automotive.
- Upper control arm optimization using modeling and Transient Structural Analysis.
- Designing and Modal analysis is performed to study the Natural Frequencies of control arm.
- Experimental testing is done to validate analysis results of optimize control arm.

4. FORCE CALCULATION

4.1 Condition I: Static Condition

The earth's gravitational pull ($mg=W$) acts through the centre of gravity and the reaction acts through the contact patches between the tires and the road in general transport vehicle. To every action there is an equal and opposite reaction Figure shows the forces on a stationary car. The vectors shown represent the combined reactions at both front wheels (R_f) and both rear wheels (R_r).

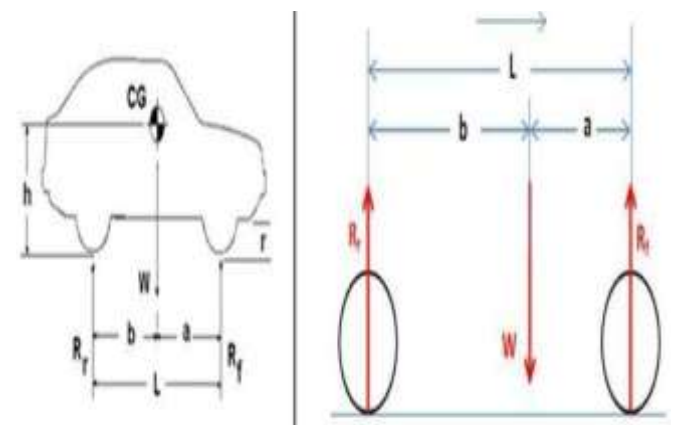

Fig 1: Forces on Stationary Car Total weight of the car = 2300 kg = 22563 N

Weight must be divided into front axle weight and rear axle weight. 52% of total weight is taken by front axle and 48% of total weight is taken by rear axle.

Weight on Front axle = 2300 * 0.52 = 1196 kg = 11732.76 N
 Weight on Rear axle = 2300 * 0.48 = 1104 kg = 10830.24 N

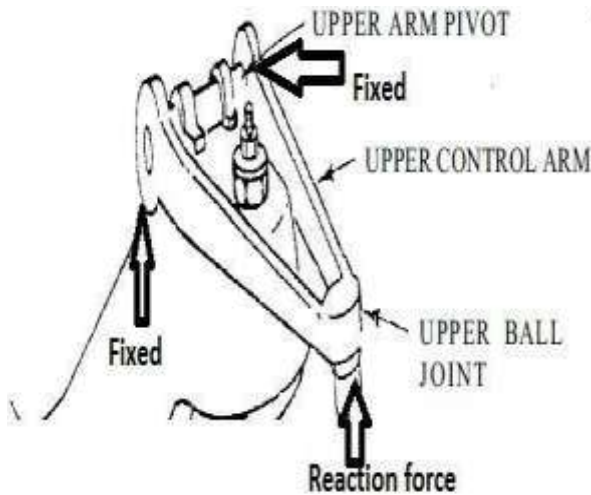

Fig 2: Boundary forces for Static Condition

4.2 Condition II: Static and Dynamic Loads

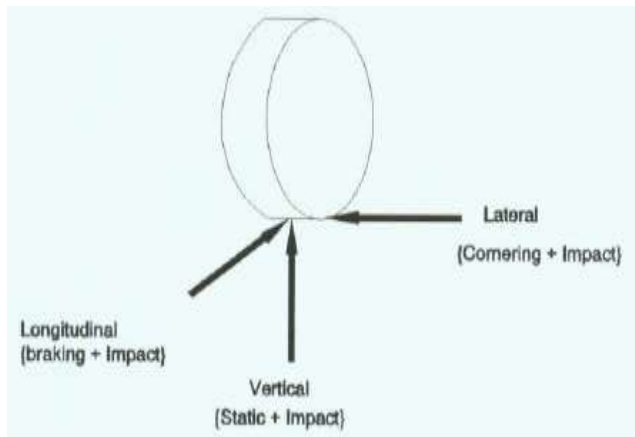

Fig 3: Wheel Loads and Directions

Table 1: Input Parameters for Load Calculations

Description	Symbol	Value
Total Weight of vehicle	W = F	22.563 KN
Weight on front axle	F1	11732.76 N
Weight in rear axle	F2	10830.24 N
Tyre rod coefficient	μ	1.45
Wheel Base	l	2680 mm
Average acceleration	ā	2.0 m/s ²
Vehicle mass	m	1680 kg
Centre of gravity height	hcg	880 mm

4.3 Front Axle Breaking Force (FB) per Wheel

We have to find the term bcg, consider a simply supported beam, where force F=22.56 KN which acts at a distance X from point A (Front end)

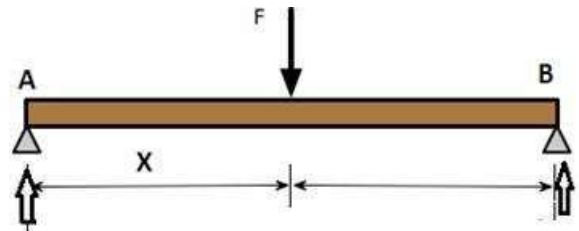

Fig 4: Force on the Axle Simply supported beam Taking moment at point A

$$\sum m_A = 22.56 * X - 10.83 * 2680 = 0 \Rightarrow X = 1286.54 \text{ mm}$$

$$bcg = 2680 - X = 1393.46 \text{ mm}$$

$$FB = \mu/2 [\text{Static} + \text{dynamic load}] = \mu/2 [W * bcg/l + m * \bar{a} * hcg/l]$$

$$FB = 9.60 \text{ KN}$$

4.4 Vertical Force (FV)

$$FV = 3/2 [\text{Static} + \text{dynamic load}]$$

$$FV = 3/2 [W * bcg/l + m * \bar{a} * hcg/l]$$

$$FV = 3/2 W [bcg/l + \bar{a}/g * hcg / l]$$

Vertical Force FV= 19.86 KN

4.5 Lateral Force (FL)

$$FL = W [\text{Static} + \text{dynamic load}]$$

$$FL = W [bcg/l + \bar{a}/g * hcg / l]$$

Lateral Force FL= 13.24 KN

4.6 Existing Material Properties

Table 2: Structural Steel Properties

Properties of Material	Value
Young's Modulus E	212 GPa
Poisson's Ratio ν	0.3
Density ρ	7865 kg/m ³
Yield Strength σ _{yield}	440 MPa
Ultimate Tensile Strength σ _{UTS}	540 MPa

5. ANALYSIS OF EXISTING UPPER CONTROL ARM OF SUSPENSION SYSTEM

5.1 Transient Structural Analysis

Transient dynamic analysis is a technique used to determine the dynamic response of a structure under the action of any general time dependant load. This type of analysis is used to determine the time-varying displacement, stress. For the analysis of existing upper control arm firstly drawing with a

evaluated dimensions is made in CATIA. After this model imported in ANSYS. Forces and boundary condition applied to the model then meshing of arm using tetrahedral element

is done and the result of the analysis shows stresses and deformation of upper control of existing material. The result obtained in analysis shown below:

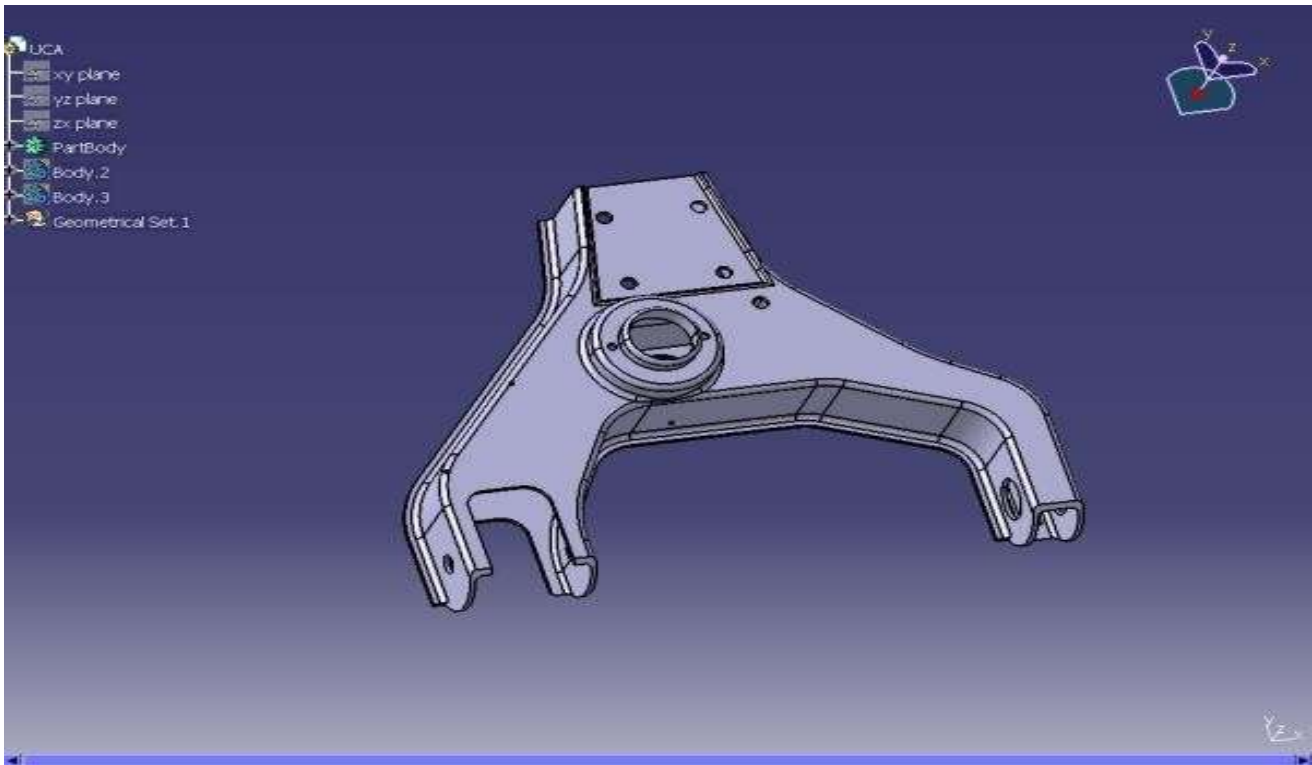

Fig 5: CATIA model of Upper Control Arm

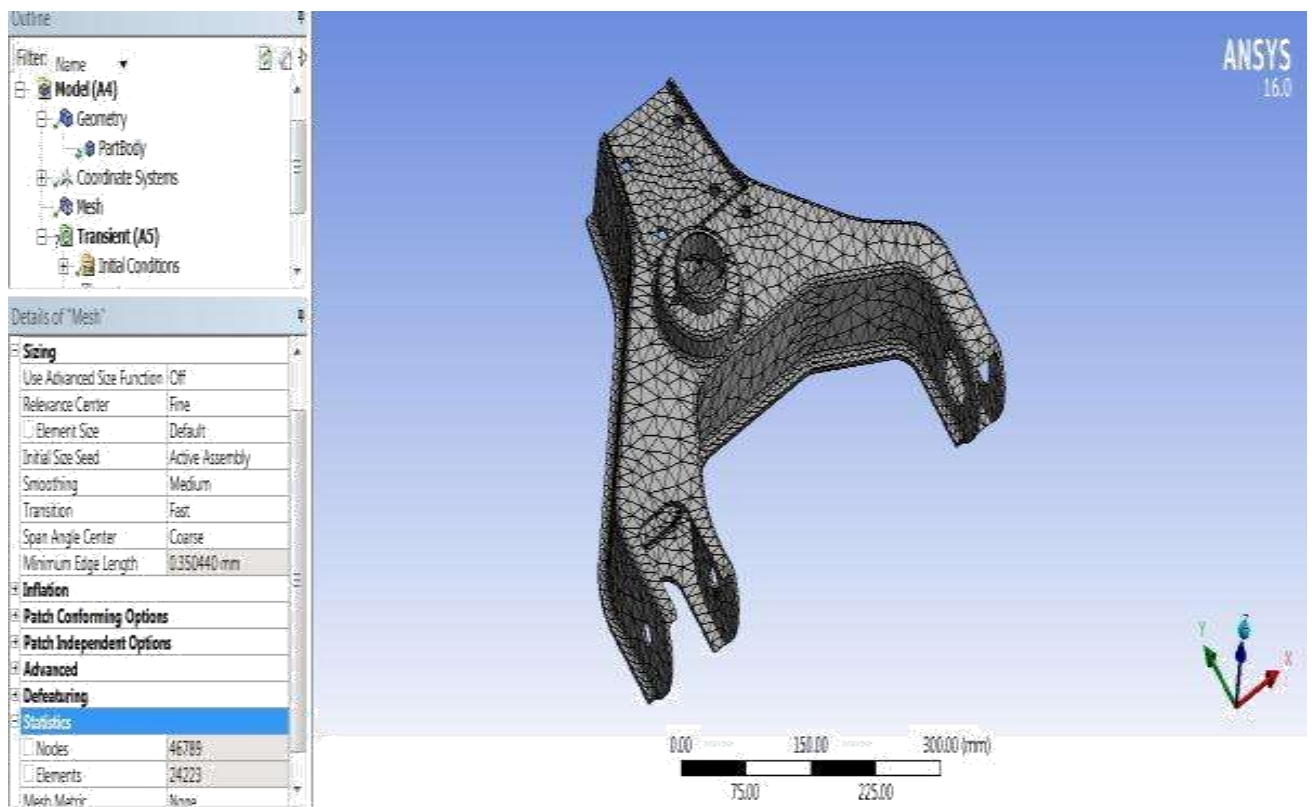

Fig 6: Meshing of Upper Control Arm using Tetrahedral Element

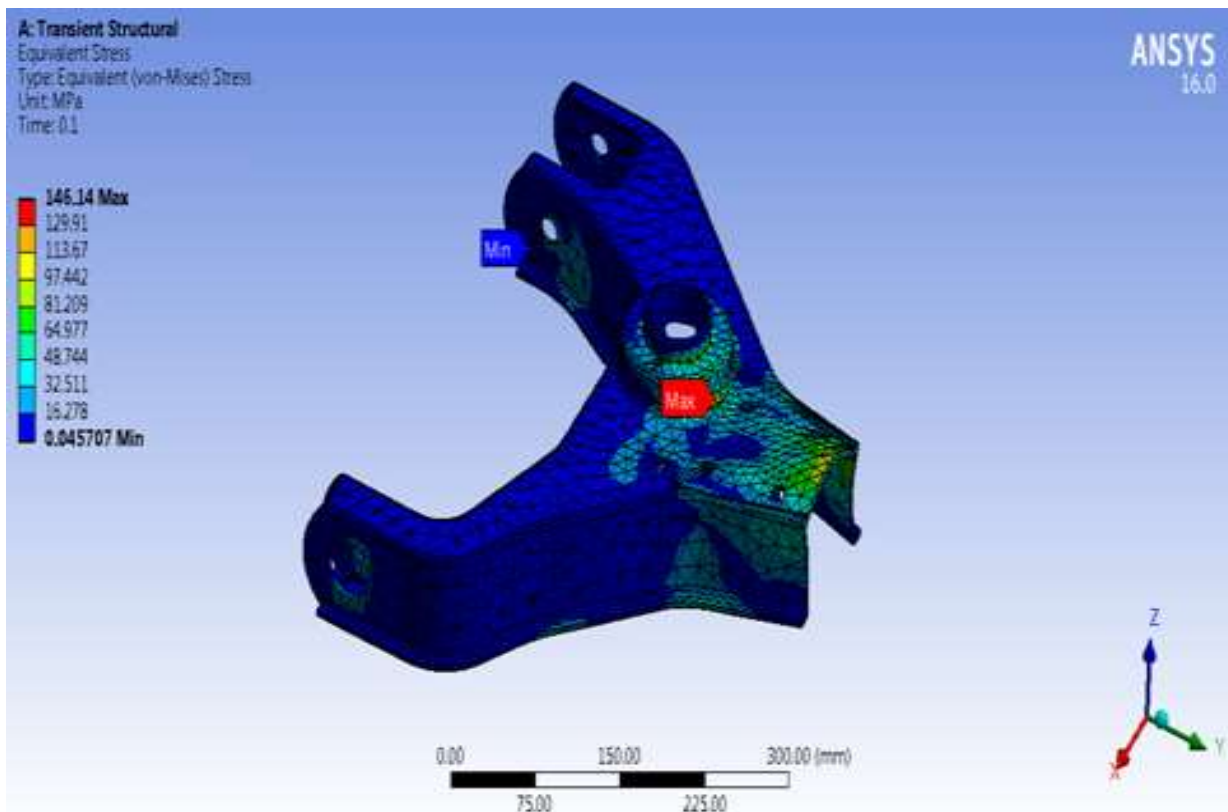

Fig 7: Von Misses Stresses on Upper Control Arm

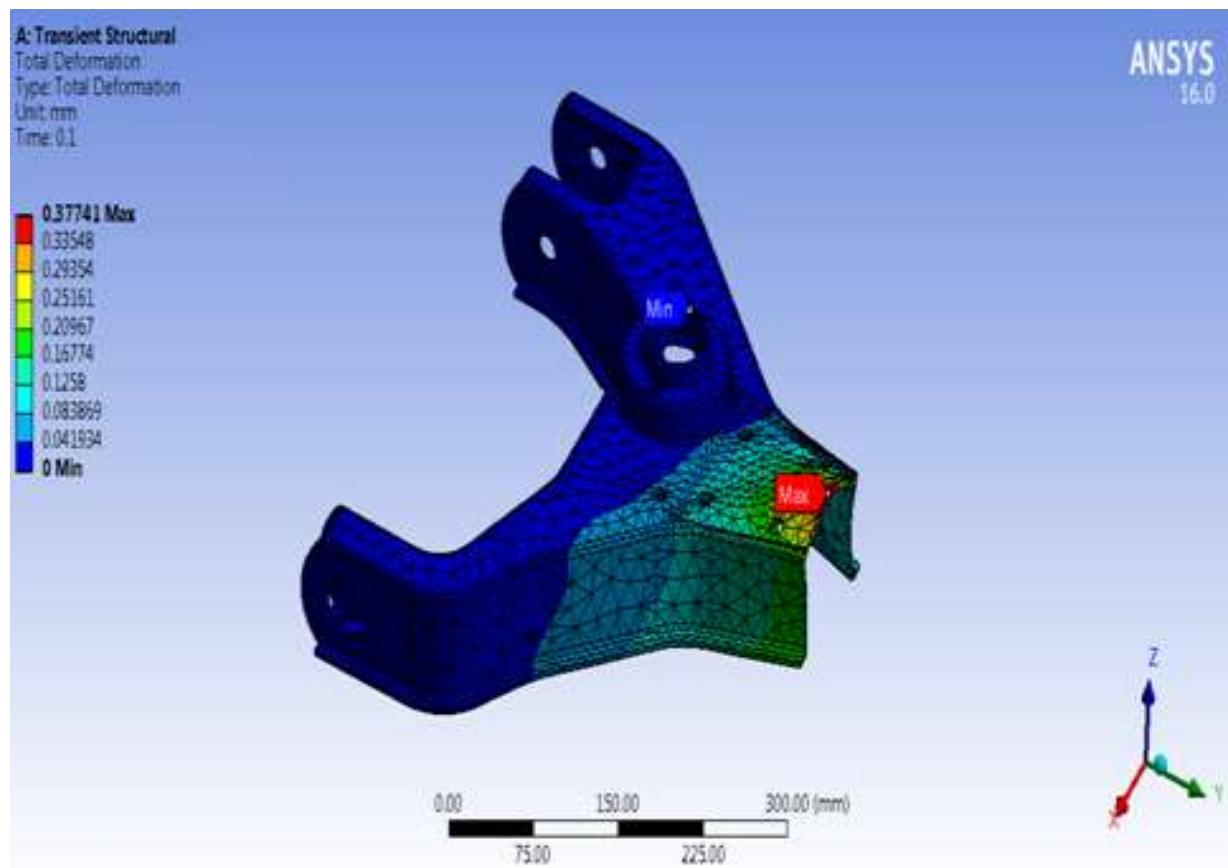

Fig 8: Deformation of Upper Control Arm

The maximum deformation 0.37741 mm and von mises stress is 146.14 MPa obtained.

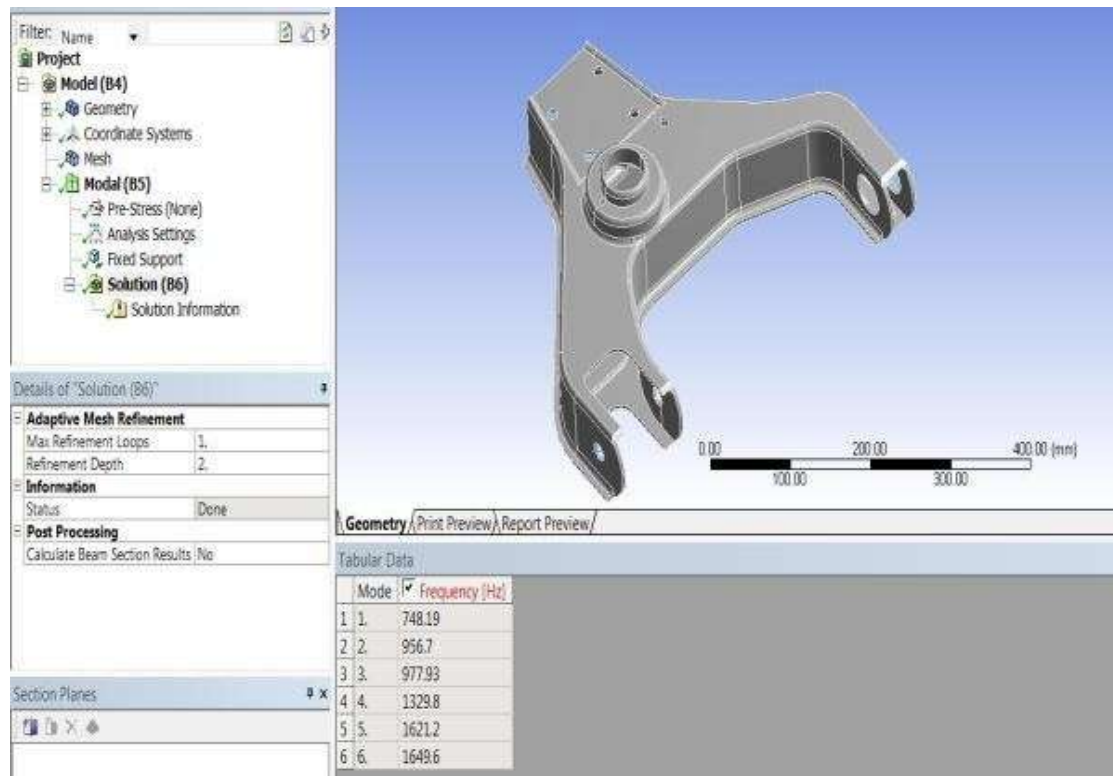

Fig 9: Natural Frequency of Upper Control Arm

5.2 Modal Analysis

The study of the dynamic properties of structures under vibrational excitation is Modal analysis. The modal analysis is obtained with different mode sets and their respective deformation. Each mode gives the vibration range in the form of frequency and maximum deformation at that

frequency level.. If a structure's natural frequency matches a component's frequency, the structure may continue to resonate and experience structural damage. 1649.6Hz maximum frequency above which chances of structural damage to the arm.

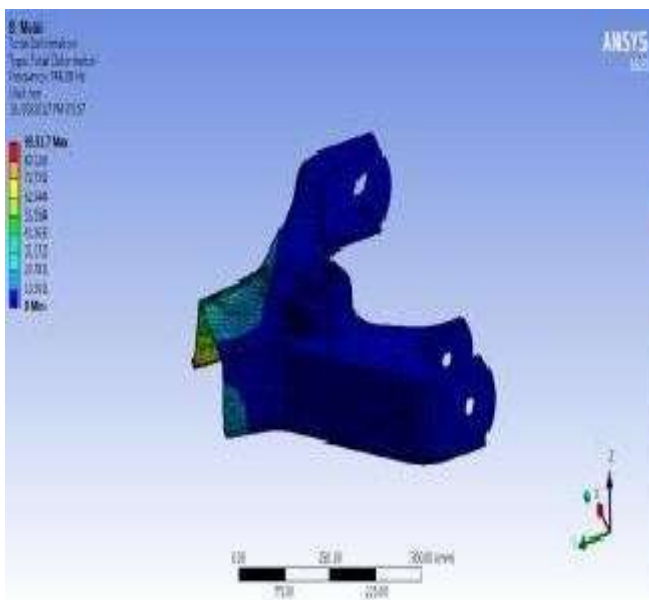

Fig 9a: Mode Shape1

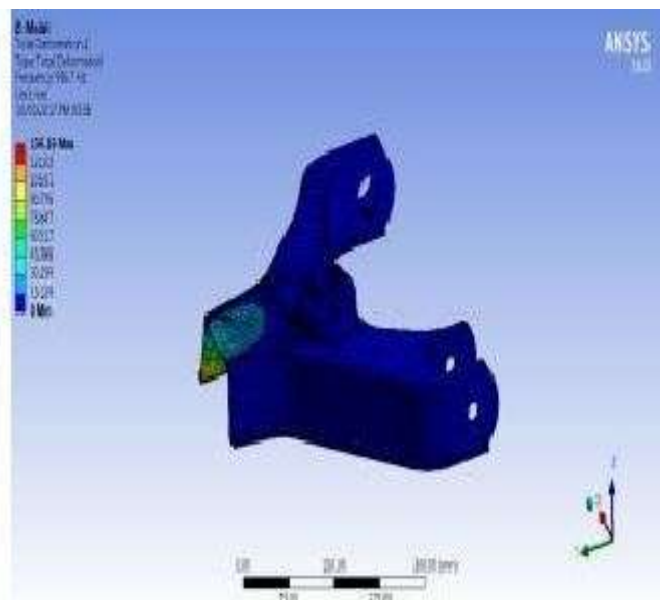

Fig 9b: Mode Shape2

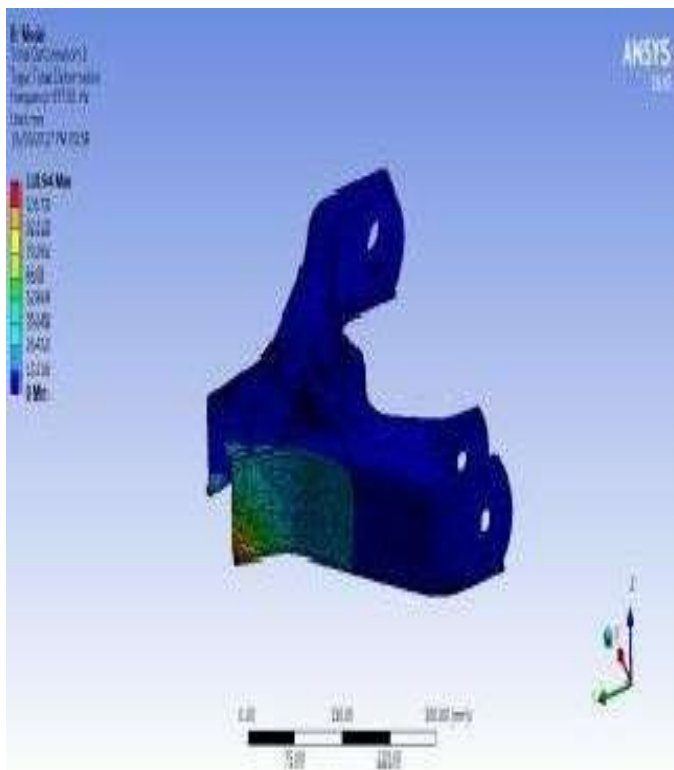

Fig 9c: Mode Shape3

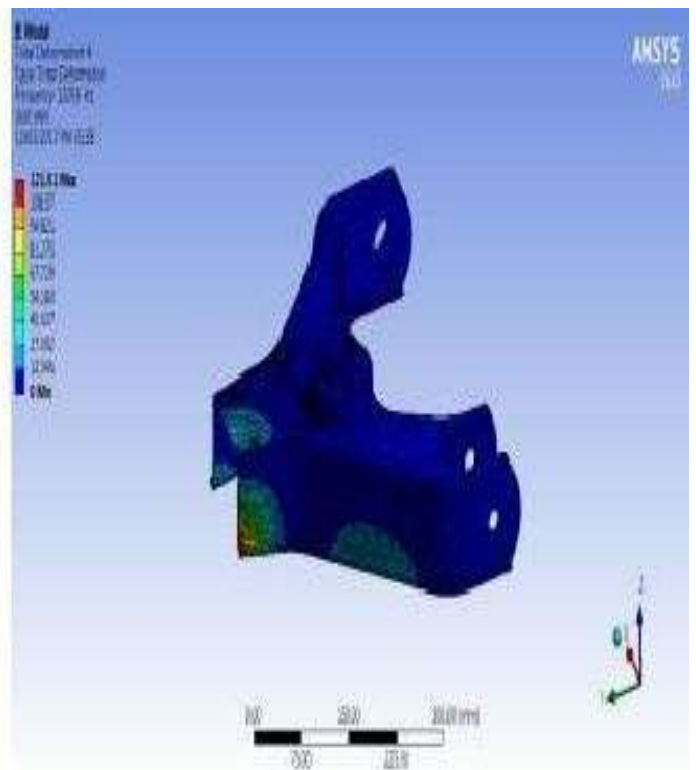

Fig 9d: Mode Shape4

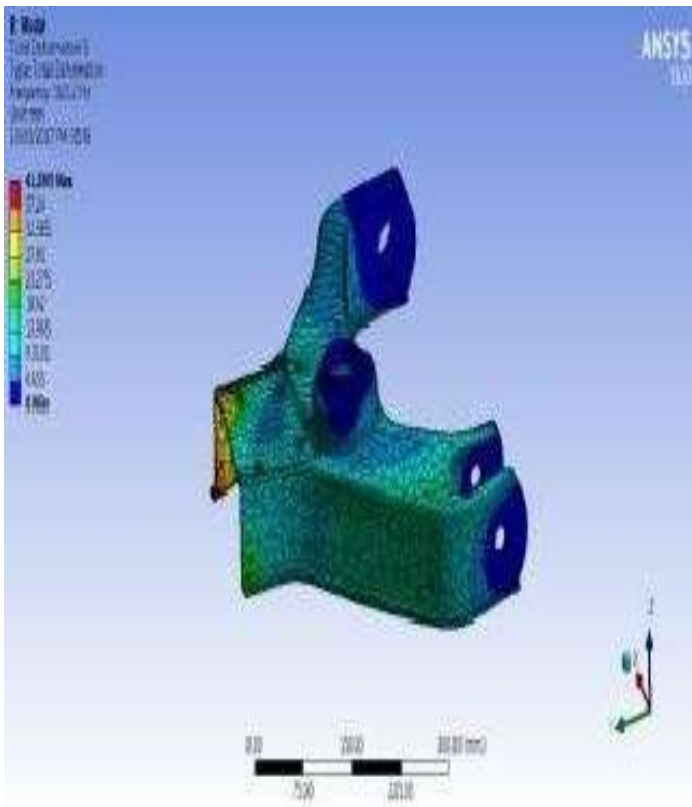

Fig 9e: Mode Shape5

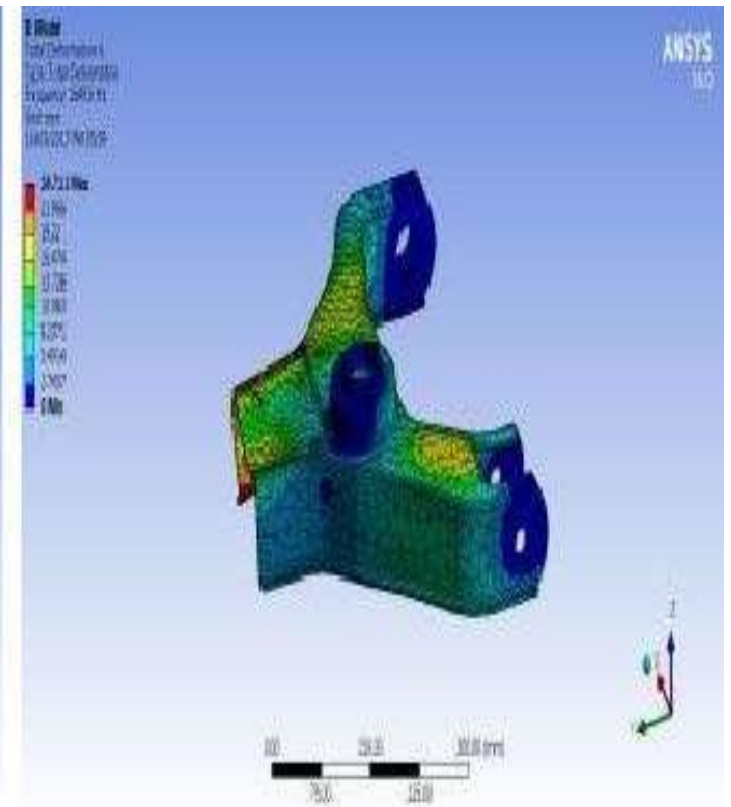

Fig 9f: Mode Shape6

Table.3: Natural frequency for existing Upper Control Arm

Mode Shape	Natural Frequency Hz	Deformation mm
1	748.19	93.517
2	956.7	136.16
3	977.93	118.94
4	1329.8	121.91
5	1621.2	41.895
6	1649.6	24.711

6. DESIGN AND OPTIMIZATION UPPERCONTROL ARM OF SUSPENSION SYSTEM

Design and Optimization is to find best possible solution under given situations. Here optimization is done considering two parameters based on profile and based on material selection.

6.1 Optimization based on Profile

Optimization based on profile in which stresses in arm are taken into consideration Profiles are made based on stresses generated in UCM and at lower stress regions material is

removed and likewise iterations are done. Pocket size to be made 35mm cc and radius 20mm Figure shown below analysis results of optimization of arm based on profile of Iteration 5. 503.8gm less weight compare to existing upper control arm. Following table shows stresses and deformation for different profile.

Table 4: Analysis results for Modified Profile

Iteration	Profile	Weight Kg	Stress MPa	Deformation mm
Iteration 1	Existing	8.8919	146.14	0.37741
Iteration 2	Profile 2	8.6631	140.54	0.38072
Iteration 3	Profile 3	8.5808	148.22	0.40546
Iteration 4	Profile 4	8.487	161.93	0.42525
Iteration 5	Profile 5	8.3881	164.8	0.48427
Iteration 6	Profile 6	8.2867	185.51	0.53295

Modified arm shown stress and deformation more than existing which is more than existing and weight reduction compare to existing. Stress for modified profile 164.8Mpa and deformation is 0.48427mm.

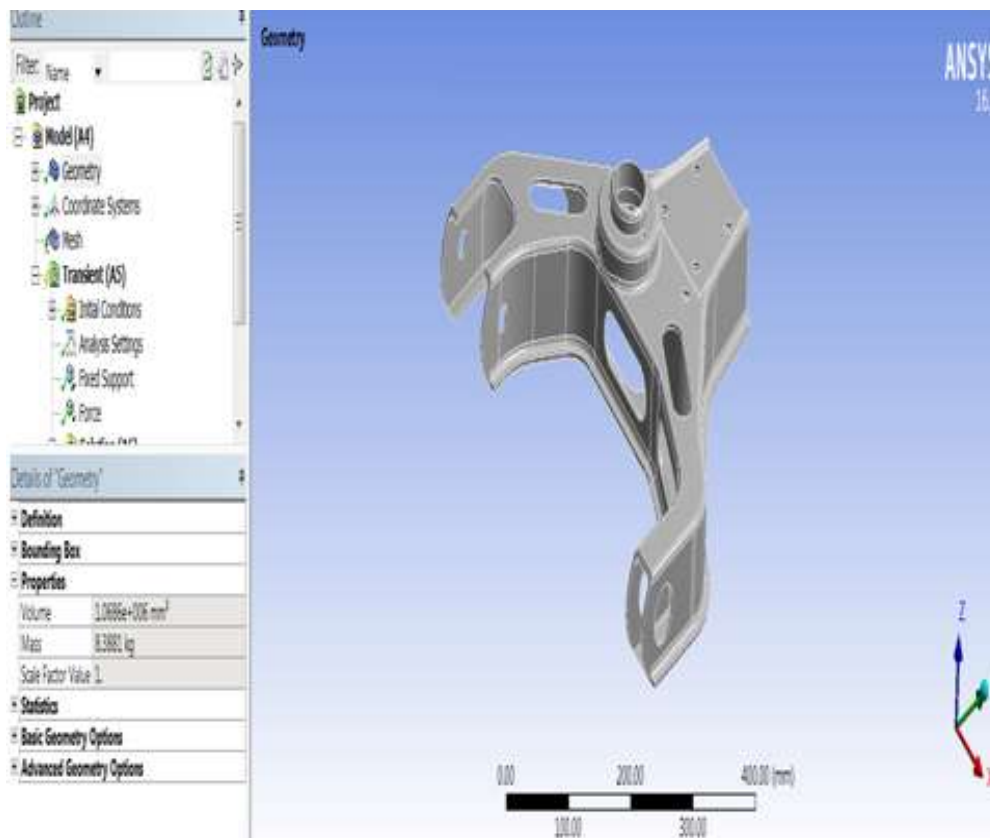

Fig 10: Upper Control Arm with Profile Modification

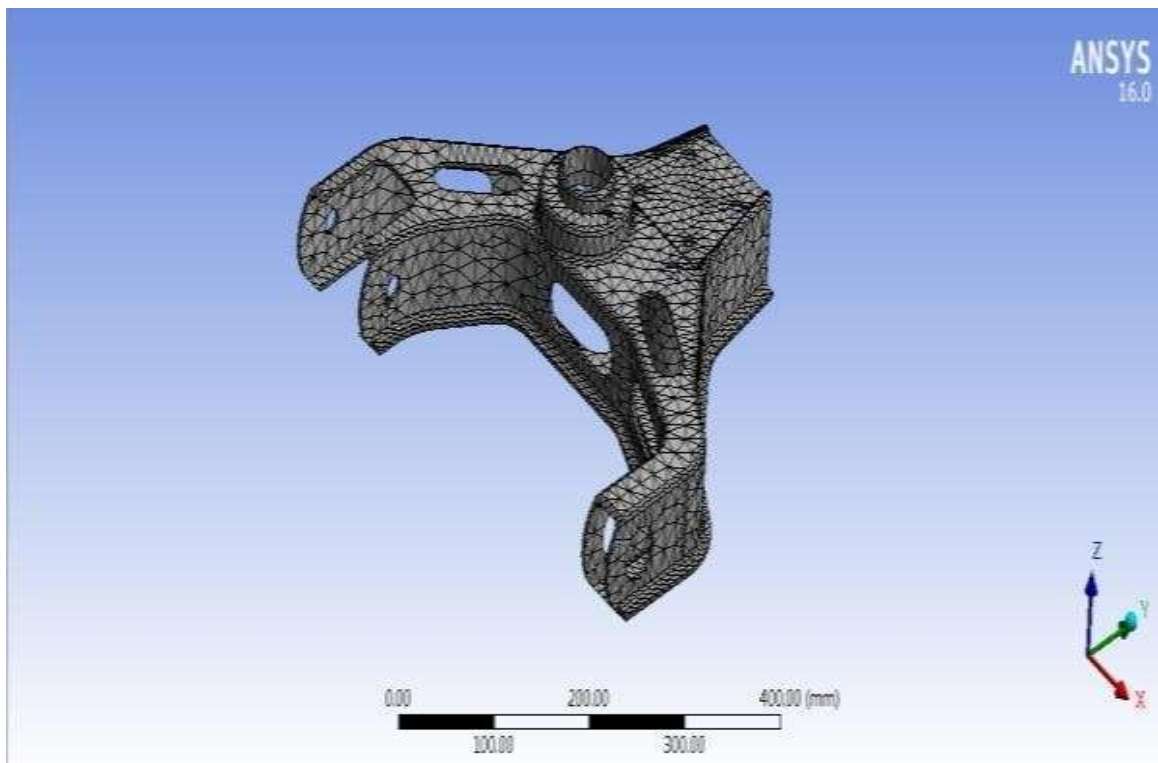

Fig 11: Meshing of UCM using tetrahedral element

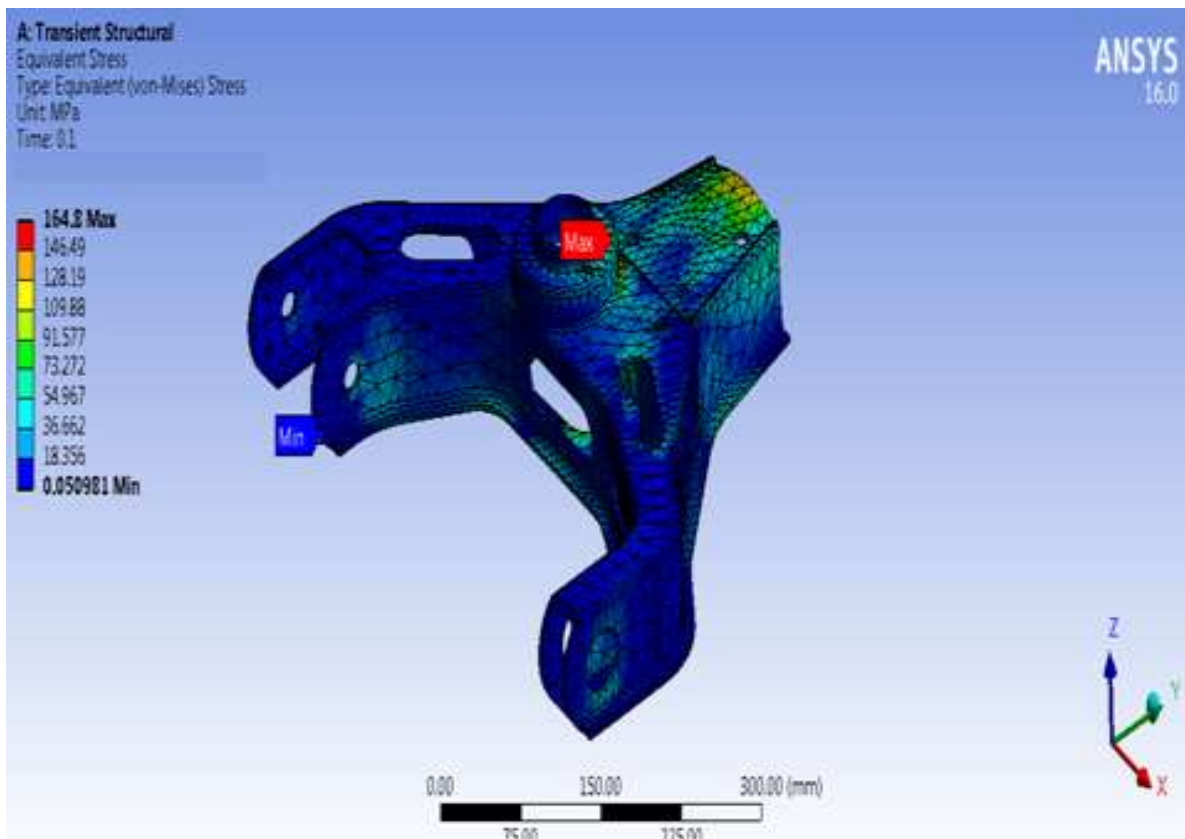

Fig 12: Von Misses Stresses on Upper Control Arm

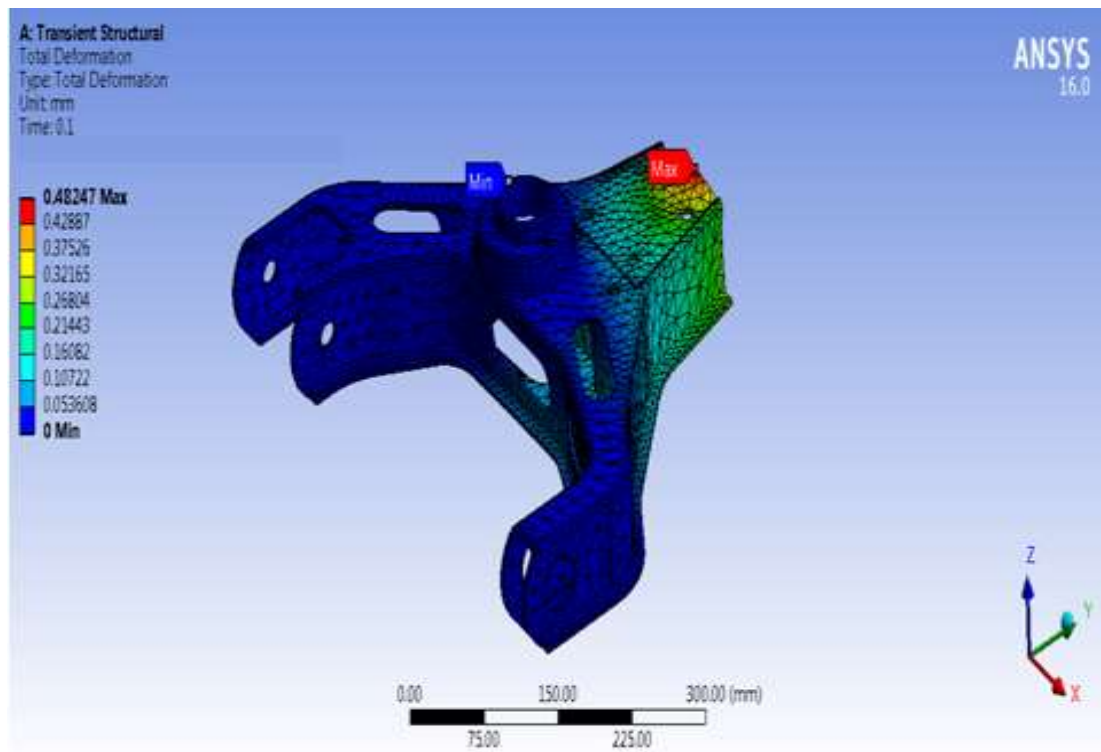

Fig 13: Deformation of Upper Control Arm

6.2 Optimization based on Material

Material Selection of Upper Control Arm

Material to be analyze to find its stress, deformation and taken into account its allowable stress for safety. Best suited material to be selected of upper control arm having better properties(to withstand crushing force). Properties of the alternative material are listed in table below:

Table.5: Properties of Various Materials

Material of UCM	Grey Cast Iron	Stain-Less Steel 321	Al Alloy	Mg Alloy AZ63 T1	Ti Alloy Ti-6Al-4V
Yield Strength MPa	450	515	310	200	880
Allowable strength MPa (FOS 2.0)	225	227.5	155	100	440
Density (ρ) kg/m ³	7100	8027	2700	1830	4430
Thermal Conductivity W/m k	55.0	20.0	167	77	6.7

Elongation at break %	15	40	12	6	14
-----------------------	----	----	----	---	----

From table results below it is stated that Stainless steel is having best result compared to other materials. Deformation above 1 mm is not accepted. Aluminium and Magnesium has more stress induced than allowable hence can't be considered. Stainless steel has 11.58 % less weight and 11.36 % less stresses. Also has higher allowable strength than structural steel. Therefore selected for testing on UTM.

Table 6: Ansys Results of Various Materials

Material of UCM	Allowable Strength MPa	Stress MPa	Deformation mm	Weight kg
Structural Steel (Existing)	220	146.14	0.37741	8.919
Gray Cast Iron	225	183.31	0.961	7.6936
Stainless Steel 321	257.5	131.24	0.55002	7.9928
Aluminium Alloy 6061	155	178.51	1.4841	2.9599
Magnesium Alloy AZ63 T1	100	192.41	2.3232	1.9234
Titanium alloy (Ti-6Al-4V)	440	176.27	1.1016	4.9367

6.3 Modal Analysis of Optimized Upper Control Arm for Breaker

Table 7: Natural frequency and Deformation of Optimized arm

Mode Shape	Natural Frequency Hz	Deformation mm
1	409.3	54.979
2	660.36	57.311
3	786.42	97.111
4	890.49	110.09
5	1001.2	120.27
6	1102.7	65.422

7. EXPERIMENTAL TESTING

A universal testing machine (UTM), also known as a universal tester, is used to test the tensile strength and compressive strength of materials.

7.1 Machine Specifications UTM

Table 8: UTM Specifications

Max Load Capacity	100 KN
Load Accuracy	Within +/- 1%
Test Space	
Tensile	680 mm
Compression	620 mm
Piston Stroke	250 mm
Dimensions	700*610*2200 mm
Power Supply	Three-Phase, 240V-50HZ



Fig 14: Testing of Arm on UTM

7.2 Experimental Test Results for Stainless Steel 321

Testing of Upper control arm having Stainless Steel 321 material shown in table below:

Table 9: Test Result on UTM

Weight (kg)	Material	Deflection, mm(Experimental)			
		Trial 1	Trial 2	Trial 3	Avg
7.9928	Stainless Steel 321	0.57	0.58	0.58	0.577

8. RESULT AND DISCUSSION

Upper control arm existing model is analyzed stresses and deformations are found. Maximum von mises stress found to be 146.14MPa and deformation found to be 0.37741. Then Optimization of arm for mining crusher is to be done based on profile by making pocket in number of iterations and then selecting best suited material. The maximum stress value for optimized upper control arm for crusher is 131.24MPa. Stresses are less than existing. The final optimized model is capable of handling the loading condition for construction site under safe limit. Deformation of optimized upper control arm is 0.55002. A comparative study of FEA and experimental result shows 4.58% error. Optimization reduced the final weight with good strength of upper control arm at obtained boundary condition. Stainless steel 321 is best alternative material to existing one. Modal analysis for optimized mining control arm showed less frequency than existing upper control arm of automotive vehicle .

9. CONCLUSION

FEA and optimization techniques can be used for effective performance and weight reduction of mining Breaker upper control arm with better strength. Final optimized model showed stress and deformation values within safe limit and Stainless Steel having suitable alternative to existing material. Natural frequency of optimized control arm less than existing still value is allowable. Optimization of arm shows 11.58% weight reduction than existing.

FUTURE SCOPE

- Vibration testing can be done.
- Experimental testing on vehicle can be done with high end equipments and facilities.

ACKNOWLEDGEMENT

I take this opportunity to thank the people who helped me through this project. I am grateful Mr.R.N.Bhatt,Manager (Production) Sandvik Asia Pvt.Ltd, Dr.N.P.Gulhane, HOD of Mech Dept., Dr.S.S.Naik, PG Coordinator. I would like to express my sincere thanks to my guide Dr.W.S.Rathod for his valuable guidance wherever required.

REFERENCES

- [1] Jagwinder Singh, Siddhartha Saha, —Static Structural Analysis of Suspension Arm Using Finite Element Method, International Journal of Research in Engineering and Technology eISSN: 2319-1163, pISSN: 2321-7308.
- [2] Gurunath Biradar, Dr. Maruthi B H, Dr. Channakeshavalu, —Life Estimation Of Double Wishbone Suspension System Of Passenger Car, International Journal for Technological Research in Engineering Volume 2, Issue 12, August-2015, ISSN: 2347 – 4718.
- [3] A. Rutci, —Failure Analysis of a Lower Wishbone, Special issue of the International Conference on Computational and Experimental Science and Engineering, Vol. 128 (2015).
- [4] Jong-kyu Kim, Seung Kyu Kim, Hwan-Jung Son, Kwon-Hee Lee, Young-Chul Park, —Structural Design Method of a Control Arm with Consideration of Strength, proceedings of the 9th wseas int. conference on applied computer and applied computational science.
- [5] B. Sai Rahul, D.Kondaiah and A.Purshotham,—Fatigue Life Analysis of Upper Arm of Wishbone Suspension System, Journal of Mechanical and Civil Engineering, e-ISSN: 2278-1684, p-ISSN: 2320-334X, Volume 11, Issue 5 Ver. V (Sep-Oct. 2014), PP 36-40.
- [6] Prof. A. M. Patil, Prof. A.S. Todkar, Prof. R. S.Mithari, Prof. V. V. Patil, —Experimental & Finite Element Analysis of Left Side Lower Wishbone Arm of Independent Suspension System, IOSR Journal of Mechanical and Civil Engineering (IOSR-JMCE).
- [7] Lihui Zhao, Songlin Zheng, Jinzhi Feng, Qingquan Hong, —Dynamic Structure Optimization Design of Lower Control Arm Based on ESL, Research Journal of Applied Sciences, Engineering and Technology 4(22): 4871-4878, 2012, ISSN: 2040- 7467.
- [8] N.A. Kadhim, S. Abdullah, A.K. Ariffin, S.M.Beden —Fatigue Failure Behaviour Study of Automotive Lower Suspension Arm, Key Engineering Materials Vols. 462-463 (2011) pp 796- 800.
- [9] V.V. Jagirdar, M.S. Dadar, and V.P. Sulakhe,—Wishbone Structure for Front Independent Suspension of a Military Truck, Defence Science Journal, Vol. 60, No. 2, March 2010, pp. 178-183.
- [10] Y.Nadot, V. Denier —Fatigue failure of suspension arm: experimental analysis and multiaxial criterion, Elsevier, Engineering Failure Analysis 11 (2004) 485–499.