

# CFD ANALYSIS ON HEAT TRANSFER ENHANCEMENT IN 4-HOLED CORED BRICK REGENERATOR BY INDUCING TURBULENCE

Bakhirathan.A<sup>1</sup>

<sup>1</sup>M.E, Heat Power Engineering, Coimbatore Institute of Technology, Tamilnadu, India

## Abstract

The article reports on the transient heat transfer and fluid flow in the sensible heat storage device using Computational Fluid Dynamics. The geometry considered is a cylinder of 455mm length and 43mm diameter made up of mild steel material. Numerical investigations have been done for a porosity of 0.4 and inlet velocity of 2m/s which corresponds to mass flow rate of 0.0035 kg/s by use of commercial CFD software. In CFD software the three dimensional geometrical model of the cored brick heater was modelled, meshed and simulated for 4 holed cored brick which corresponds to the hole size of 13.6mm. The fluid flow was considered to be incompressible with  $k$ - $\epsilon$  model to predict turbulence, and the thermo-physical properties of fluid and solid were assumed to remain constant. Thermal performance of storage system such as charging was evaluated. A parametric study was conducted for different thermal conductivity, to simulate axial temperature variation and pressure drop across the system. Temperature simulations are carried out by input as 465K as the condition in the regenerator. The lateral and outlet condition of the regenerator are given as adiabatic and atmospheric condition. This paper represents the fluid flow across the cored brick with and without inducer, where the inducer induces the laminar flow to turbulent. Thus the fluid flows is at low Reynolds number in the laminar regime and due to the presence of the inducer the flow get transformed to higher Reynolds number in the turbulent regime. Analysis is made for without inducer, inducer at the entrance of each holes and inducer is just next to the developing length on each holes. Result of the computational analysis was made for all cases without and with the presence of inducer.

**Keywords:** Cored brick, Porosity, turbulence inducer, pressure drop, temperature drop and heat transfer etc...

\*\*\*

## NOMENCLATURE

$k$	Thermal conductivity (W/m-K) or Turbulent Kinetic energy per context ( $m^2/s^2$ )
$c_p$	Specific heat capacity (J/kg-K)
$C_{\epsilon 1}$ & $C_{\epsilon 2}$	Constants for turbulence model (1.44 & 1.92 respectively)
$P_k$	Shear production of turbulence ( $kg/m-s^3$ )
$T$	Temperature (K)
$u$	Fluid velocity (m/s)
$t$	Time (s)
Greek symbols	
$\epsilon$	Rate of dissipation of kinetic energy ( $m^2/s^3$ )
$\mu$	Dynamic viscosity ( $kg/m-s$ )
$\rho$	Density ( $kg/m^3$ )
$\sigma$	Prandtl number in $k$ - $\epsilon$ equation
Subscripts	
$f$	Fluid
$k$	Kinetic energy
$s$	Solid
$\epsilon$	Dissipation rate
$T$	Turbulent

## 1. INTRODUCTION

Heat transfer and fluid flow are two streams of science which go hand in hand. Advancement and originations in these two will unravel the problems of energy and related issues. Heat, being a form of energy, can be deliberated as a elucidation for energy crisis. Heat can be transmitted from one material or medium to another material or medium. One

such medium is porous medium. It can be attained by taut packing of small particles of similar material in a container or a vessel.

Alberto Garcia et al[1], performed the experiment on three . A performance comparison between wire coils and twisted tape inserts has shown that wire inserts perform better than twisted tapes in the low Reynolds number range 700–2500. They showed the variation of pressure and temperature under the uniform flux condition. They validated the equation through experiment data.

Bodius Salam et al[2] said heat transfer augmentation by means of Semi-circular ring turbulator with U-Cut on its periphery by inserting them in inner tube of concentric pipe heat exchanger. Turbulators (the enhancement device) is inserted inside a pipe, the obstruction hence experienced by fluid flow causes a major change in flow pattern, its behaviour and properties. They focused on overcoming the limitation in the ring type turbulators by improving heat transfer at the cost of lesser pressure drop.

Karaki et al (2011)[3], performed experiments on heat transfer of charging and discharging in a packed bed thermocline storage tank. They formulated dimensionless governing equations of energy for heat transfer fluid and solid packed bed material. The working medium used for the experimentation was Xceltherm 600 Synthetic oil. River pebbles and pea pebbles were taken as heat storage material. They validated their governing equations using the experimental data.

M.M.K. Bhuiya et al[4](2013), found the experimental results for heat transfer and pressure drop for the case when two three start spirally corrugated tubes were combined with five twisted tape inserts with different relative pitches. In Re: 3000-60000; the heat transfer and pressure drop was obtained significantly higher compared to smooth tube under same operating conditions. The isothermal friction coefficient showed a falling trend for straight and swirl flow when the relative pitch decreases.

Panida and Smith [5](2012), visualized the flow characteristics induced by twisted tape consisting of alternate-axis has been comparatively investigated to that induced by typical twisted tape. The visualization as carried out via a dye injection technique. Results is consistent with the superior heat transfer at smaller twist ratio.

Prasad et al (2014)[6], predicted the performance of high temperature sensible heat storage (SHS) models of 50 MJ capacity designed for solar thermal power plant applications in the temperature range of 523 K - 648 K. The SHS unit acts as a regenerator type heat exchanger which stores/releases heat on passing hot/cold HTF through the tubes embedded into it. A mathematical model of cylindrical configuration with embedded multi-tube was developed employing concrete and cast steel as storage mediums.

Ezhilarasu and Krishnan (2013)[7], performed experimental and simulation analysis on porous media in which the porous media is fully packed with spheres in their experiment. They used porous media with porosity ranging from 0.46 to 0.5 and with hot air whose temperature varies from 90 to 190°C. The velocity of air they considered for their experiments is 2 to 6 m/s. Also the simulation is also done by using CFD techniques. For their simulation, they made inlet temperature as constant and fixed between 100 to 300°C.

Gokul and Krishnan (2015)[8], performed simulations on cored brick heaters and pebble bed heaters and compared the results for the same inlet temperature and fixed porosity of 0.4. The simulation was done by using CFD techniques.

Dutta and Hossain (2005)[9], Circular tube equipped with perforated twisted tape insert with different porosities ( $R_p$ ) are used in experimental investigations. The examination was conducted for the turbulent flow regime i.e. Re 7200-49800 using air as working fluid under uniform wall heat flux boundary condition. As far as influence of porosity is concerned, the presence of strong swirl intensity causes more efficient interruption of boundary layer along the flow path; thus at 4.5% value of porosity and at Re 7525; a maximum performance of 59% was achieved.

This report explains the variation of pressure and temperature in the 4Core brick regenerator. The velocity profile in the turbulent regimes turns a good picture for the fluid flow analysis. The comparison of pressure and temperature variation for 4Cored brick regenerator without,

with the presence of inducer at the entrance and after the developing length helps to identify the best position for placing the inducer to induce the turbulence in the laminar flow and all cases are performed by maintaining the porosity of 0.4.

## 2. MODELLING OF CORED BRICK REGENERATOR

In the present study the three dimensional geometry is created using SOLIDWORKS software, the pre-processor used to construct the flow geometry, along with the mesh generation for solving the continuity and the equation of motion. The storage model has been solved by using commercial CFD software with package FLUENT, to solve the equations by numerical methods for the geometry constructed.

A solid cylinder of diameter 0.043m and length 0.455m with through holes of 4 holes of 0.0136m diameter was created and the porosity is maintained to 0.4. In the presence of the inducer the dimension of the inducer are maintained that the height of the inducer is  $1/2^{\text{th}}$  of the hole diameter and diameter of the inducer is of  $1/10^{\text{th}}$  of the hole diameter.

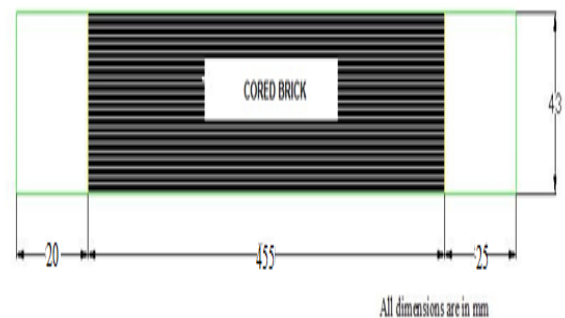

**Fig-1:** Sketch of Cored brick of CFD analysis

**Table-1:** Specification of Cored brick Regenerator

Total length of pipe (L)	500mm
Diameter (D)	43mm
Inlet length	20mm
Length of cored brick	455mm
Outlet length	25mm

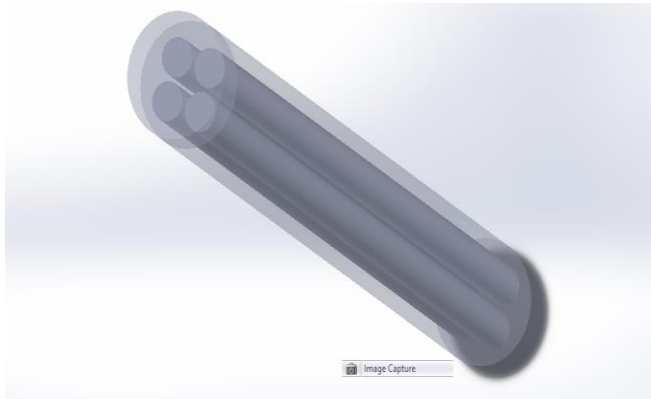

**Fig-2:** Model of 4 Cored brick without inducer

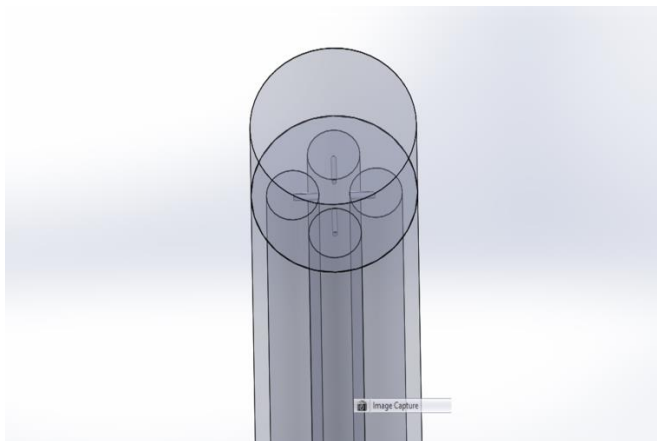

**Fig-3:** Model of 4 Cored brick with inducer at the entrance

**Table-2:** Thermo-physical property of the Cored brick

Property	Air	Mild Steel
Density (kg/m <sup>3</sup> )	1.225	7801
Specific heat (J/kg K)	1006.43	473
Thermal conductivity (W/m-K)	0.0242	43
Dynamic Viscosity (kg/m-s)	1.79 x 10 <sup>-5</sup>	-

**Table 3:** Specification of Inducer

Turbulence inducer	
Length of inducer	1/2 <sup>th</sup> of the hole diameter (D)
Diameter of inducer	1/10 <sup>th</sup> of the hole diameter (D)

### 3. ASSUMPTIONS

The following assumptions were made in the CFD analysis:

- The fluid flow is incompressible
- Friction factor is not taken in to account
- Radiative heat transfer effects are negligible.
- The thermos-physical properties of fluid and solid phases are constant through the analysis during the temperature rage investigated.

### 4. GOVERNING EQUATION

In this present work, 3D unsteady, incompressible, k-epsilon turbulence flow model is used to describe the thermal behavior and fluid flow of the system. ANSYS FLUENT solves governing equations for fluid flow and heat transfer through cored brick storage system as follows:

Fluid Flow

Continuity:

$$\nabla \cdot \vec{u} = 0$$

Momentum:

$$\rho_f \frac{D\vec{u}}{Dt} = -\nabla P + \mu \nabla^2 \vec{u}$$

Standard k-ε turbulence model:

Kinetic energy equation

$$\rho_f (\vec{u} \cdot \nabla) k = \nabla \cdot \left( \left[ \mu + \frac{\mu_T}{\sigma_k} \right] \nabla k \right) + P_k - \rho_f \varepsilon$$

Dissipation rate equation

$$\rho_f (\vec{u} \cdot \nabla) \varepsilon = \nabla \cdot \left( \left[ \mu + \frac{\mu_T}{\sigma_\varepsilon} \right] \nabla \varepsilon \right) + C_{\varepsilon 1} P_k \frac{\varepsilon}{k} - C_{\varepsilon 2} \rho_f \frac{\varepsilon^2}{k}$$

Shear production of turbulence,

$$P_k = \mu_T [\nabla \vec{u} : (\nabla \vec{u} + (\nabla \vec{u})^T)]$$

Turbulent viscosity,

$$\mu_T = \rho_f C_\mu \frac{k^2}{\varepsilon}$$

Heat Transfer

Energy equation:

Convection: Solid – Fluid Interface

$$\rho_f c_{pf} \frac{DT}{Dt} = k_s \nabla^2 T$$

Conduction: Solid Region

$$\rho_s c_{ps} \frac{\partial T}{\partial t} = k_s \nabla^2 T$$

### 5. BOUNDARY CONDITION

The conditions were applied for cored brick storage system, initially, all the domains were at assumed to be at a constant temperature of 300 K. Inlet was specified as velocity inlet, which was set as uniform air velocity with appropriate temperature. Outlet was specified as pressure outlet, which fixes static pressure as 1.013x10<sup>4</sup> Pa. Outer surface of storage system was insulated to reduce heat loss from storage system was set as zero heat flux.

This problem was solved by using commercial CFD software package, FLUENT. The set of governing equations was solved in a segregated fashion, which means that the discretized momentum and energy equations were solved one by one during the iterations. Unsteady state was formulated as first order implicit condition and cell based gradient option was considered. Velocity and pressure coupling were handled with SIMPLE algorithm. These equations are held to discretization schemes by setting pressure as PRESTO, Momentum, Turbulence kinetic energy and dissipation rate and energy are kept as First order upwind.

This problem is made under-relaxation factors Pressure as 0.3, Density as 1, Body forces as 1, Momentum ranges from 0.2 - 0.4, Volume fraction as 0.4, Granular temperature as 0.2, Turbulent kinetic energy as 0.8, Turbulent dissipation rate as 0.8, Turbulent viscosity as 1.

Simulation was carried out for the different number of holes with inlet velocity conditions 2 m/s and temperature 465K for cored brick storage system to predict the pressure drop, and axial temperature distributions.

## 6. RESULTS AND DISCUSSION

Analysis is made by the inlet condition as mentioned in the above sessions, inlet conditions are as 2m/s of bulk velocity inlet temperature as 465K and outer walls are kept as adiabatic where there is no heat flux. In the heat exchanger process is carried out by minimum pressure drop and maximum temperature drop. Thus the flow of low Reynolds number of laminar profile is passed to the cored brick. In general case of without having any inducer in the flow may expect the flow to be smooth and gradually tending to develop with in the specified length.

In the presence of the inducer even the inlet flow is at laminar regimes at low Reynolds number, inducer plays a major role in disturbing the flow which impact son the increase of the Reynolds number which tends to have the flow as turbulent. The turbulent infers the unsmooth-ness in the flow which increases the heat transfer rate and mean while increases the pressure drop. The pressure drop is limited in the general case as without inducer. The velocity profiles, pressure variation and temperature variation for different case as with and without the presence of the inducer are shown as follows,

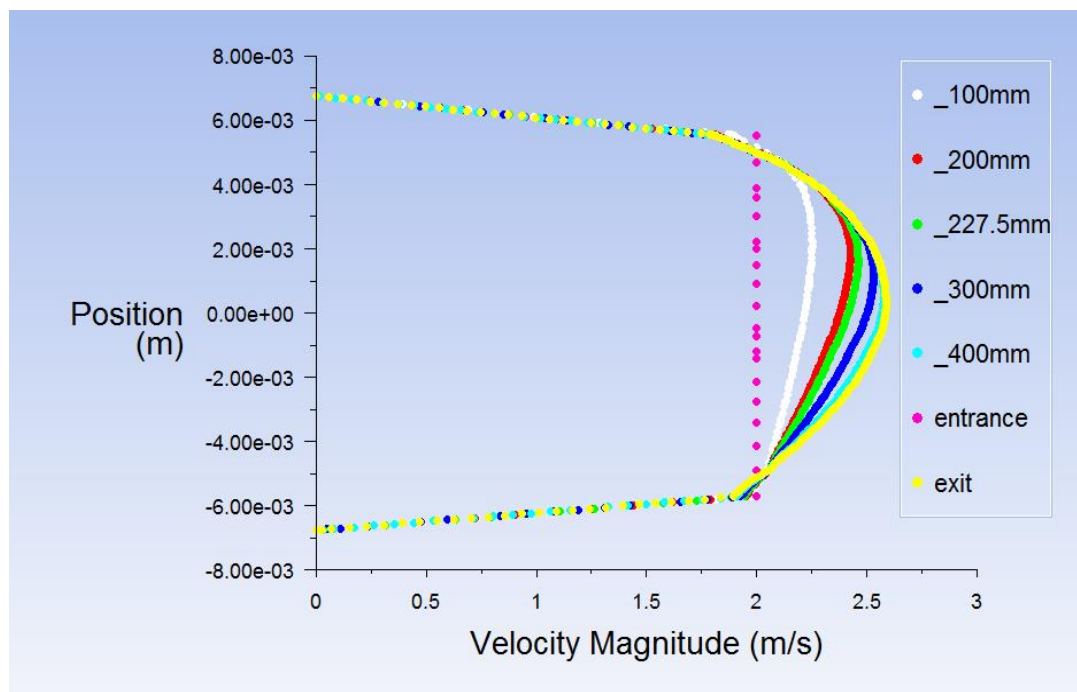

**Fig-4:** Velocity profile of 4Cored brick regenerator without inducer at different position

Figure 4, shows the velocity profile at the different length along radial direction, for the representative single hole in the 4Cored brick without inducer. The inlet bulk velocity gradually gets developed the flat velocity profile at the inlet turns to parabolic velocity profile. The gets developed with in the length of the Cored brick.

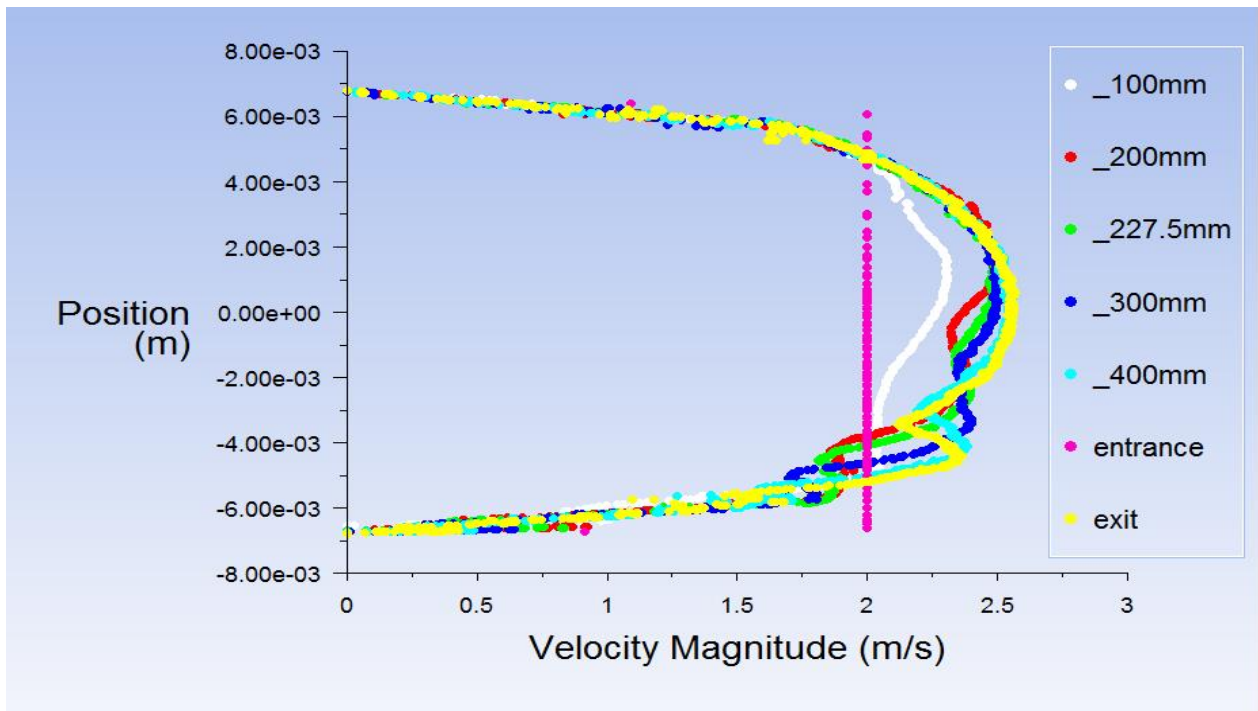

**Fig-5:** Velocity profile of 4Cored brick regenerator with inducer at the entrance at different position

Figure 5, shows the velocity profile at the different length along radial direction, for the representative single hole in the 4Cored brick with the presence of the inducer at the

entrance. The flat profile of velocity at the inlet gets rugged due the presence of the inducer at the inducer where the flow gets smooth after some distance along the axial length.

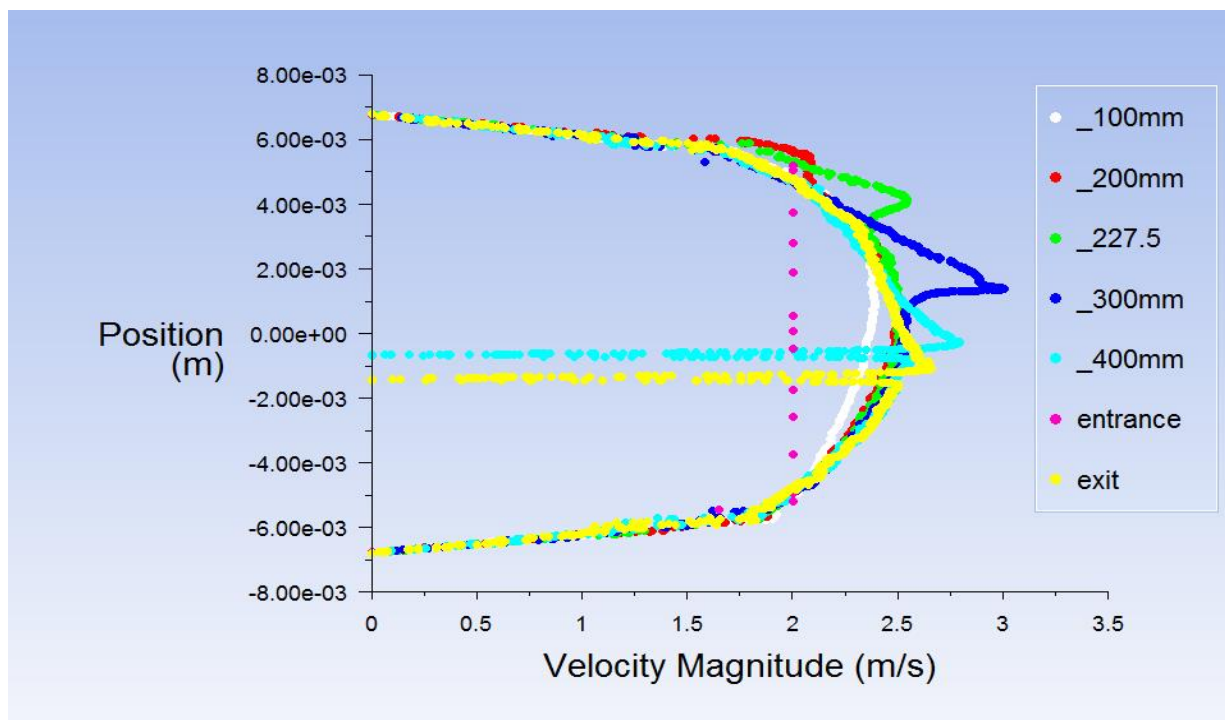

**Fig-6:** Velocity profile of 4Cored brick regenerator with inducer just after the developing length at different position

Figure 6, shows the velocity profile at the different length along radial direction, for the representative single hole in the 4Cored brick with the presence of the inducer just after the developing length. The flat velocity profile at the inlet

gets developed at the length 0.16m from the inlet. The inducer at that position disturbs the flow and induces the turbulence.

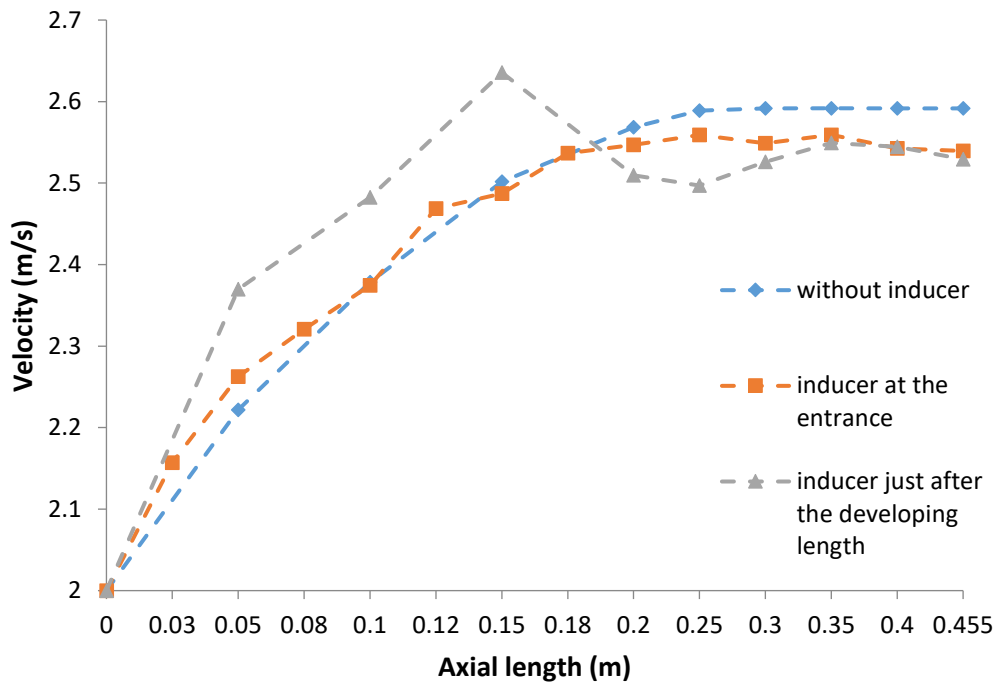

**Chart-7:** Axial velocity variation for different position of inducer and without inducer in 4Cored brick regenerator

Chart 7, shows the velocity variation along the axial direction, for the representative single hole in the 4Cored brick for all with and without the presence and different position of the inducer.

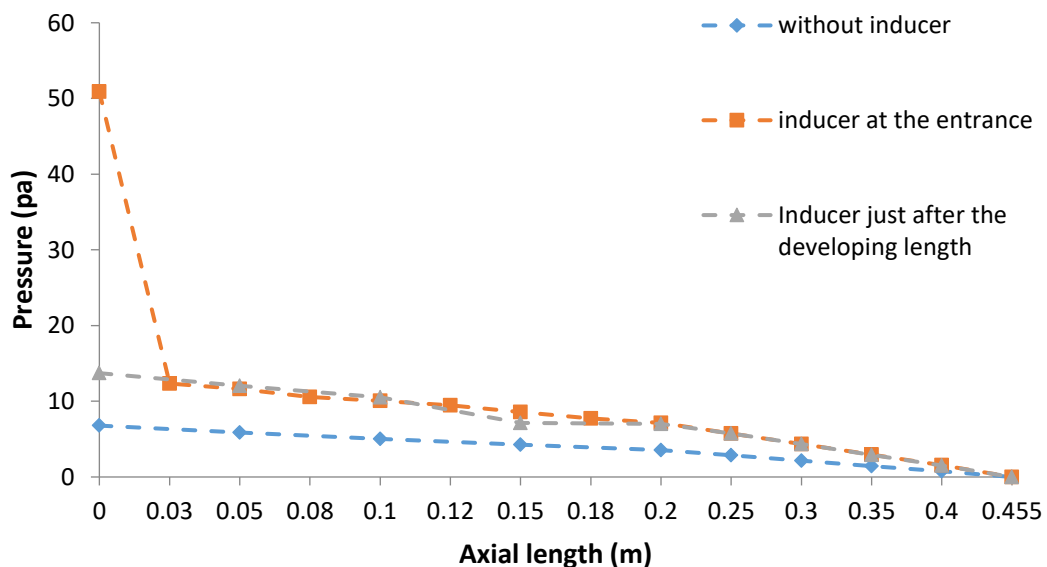
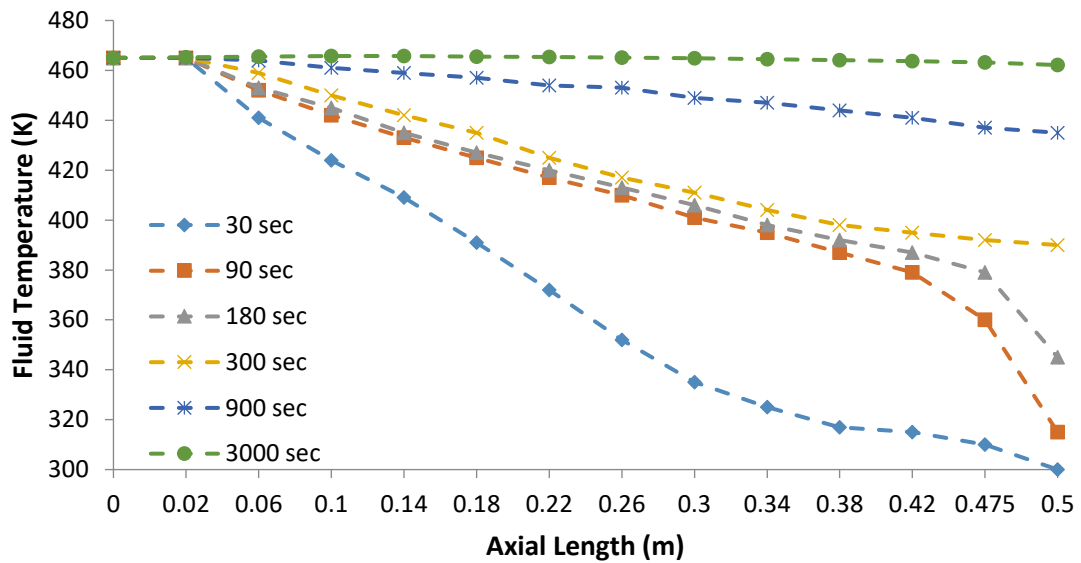

**Chart- 8:** Pressure variation along axial length for different position of inducer and without inducer in 4Cored brick regenerator

Chart 8, shows the pressure variation along the axial direction, for the representative single hole in the 4Cored brick for all with and without the presence and different position of the inducer. Pressure drop is high when the inducer is at the entrance by 5% from the case without

inducer. The pressure drop in the core brick without inducer is low and in the brick with the inducer just after the developing length is intermediate between the other two cases.

### 6.1 Temperature Distribution



**Chart-9:** Average fluid temperature variation in 4Cored brick regenerator without inducer at different time

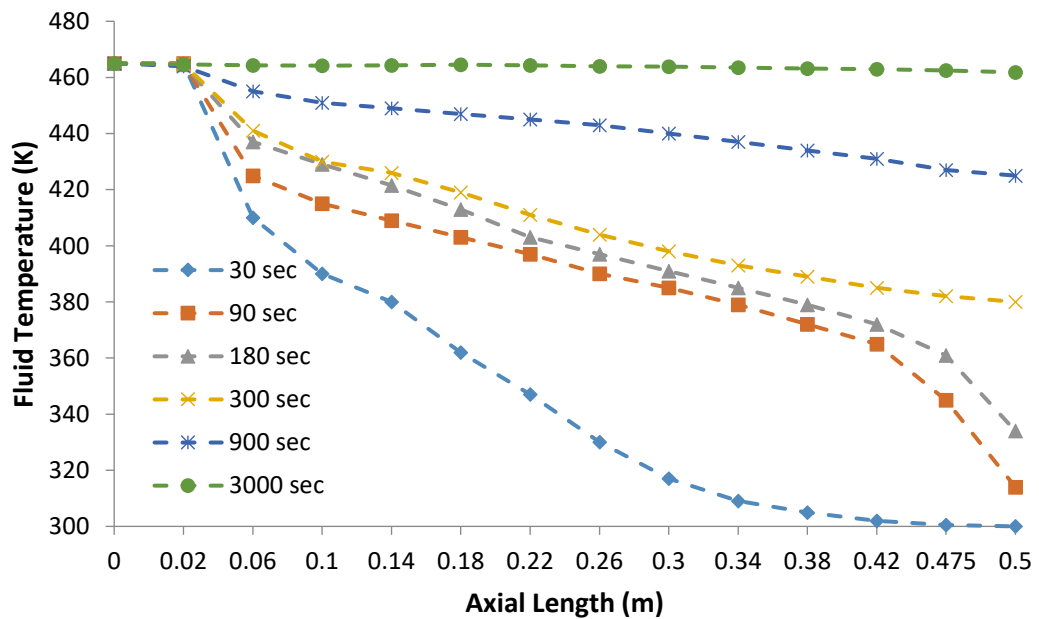

**Chart-10:** Average fluid temperature variation in 4Cored brick regenerator with inducer at the entrance at different time

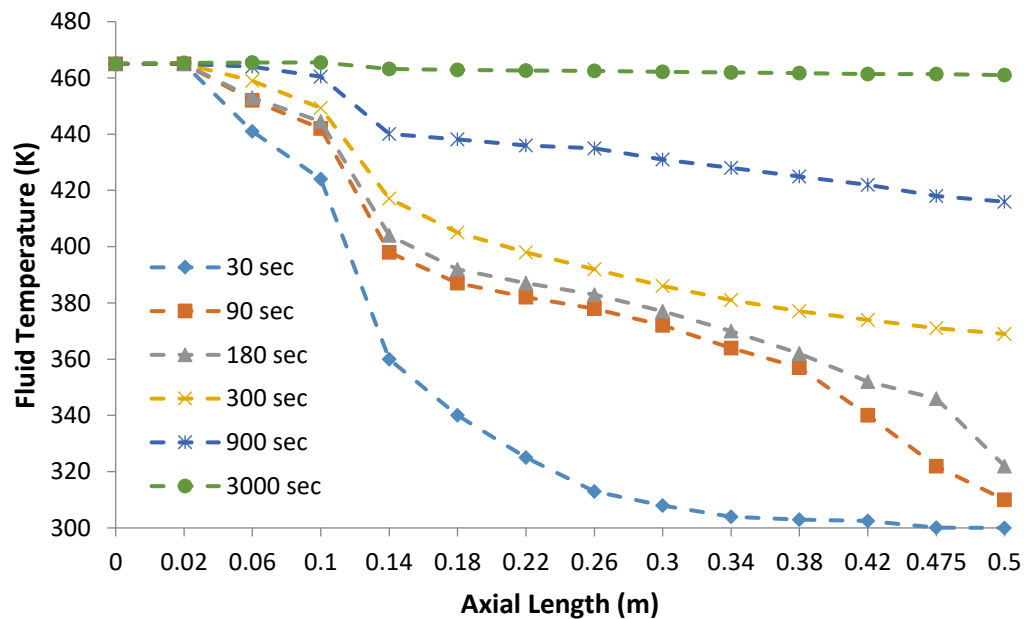

**Chart-11:** Average fluid temperature variation in 4Cored brick regenerator with inducer just after the developing length at different time

Chart 9, 8 & 10, shows the average fluid temperature variation in 4Cored brick without the presence of the inducer at the entrance and inducer just after the developing length at different time interval. Temperature drop across the fluid domain at the various time span tells that gradually the fluid get energized. Temperature drop is more in the brick with the inducer just after the developing length makes in highest heat transfer rate.

## 7. CONCLUSION

The transient hydro dynamic and thermal analysis for the mentioned specification of Cored brick were developed and analyzed by the Computational Fluid Dynamics. The pressure drop and temperature drop for the 4Cored brick regenerator with the presence of inducer at the entrance, just after the developing length and without inducer are shown above. These three cases are compared with same porosity while the time taken to attain the maximum temperature is high in the case where there is no inducer as compared with the other. Hence the presence of inducer induces the turbulence in the flow which tends to increase the heat transfer. Thus inducer at the entrance is not much effective when compared with the inducer position just after the developing length, as the drop in pressure is low. The inducer position just after the developing length yields at low pressure drop and high temperature drop when compared with the inducer at the entrance of the 4Cored brick regenerator.

## REFERENCES

- [1]. Alberto Garcia, Juan P. Solano, Pedro G. Vicente, Antonio Viedma, "Enhancement of laminar and transitional flow heat transfer in tubes by means of wire coil inserts". *International Journal of Heat and Mass Transfer* 50 (2007) 3176–3189.
- [2]. Bodius Salam, Sumana Biswas, Shuvra Saha, Muhammad Mostafa K Bhuiya, "Heat transfer enhancement in a tube using rectangular-cut twisted tape insert". 5th BSME International Conference on Thermal Engineering.
- [3]. Pei Wen Li, Jon Van Lew, Wafaa Karaki, Cho Lik Chan, Jake Stephens and James. E. O'Brien (2011), "Transient Heat Transfer and Energy Transport in Packed Bed Thermal Storage Systems", *Developments in Heat Transfer*, Dr. Marco Aurelio Dos Santos Bernardes (Ed.), ISBN: 978-953-307-569-3.
- [4]. M.M.K. Bhuiya, M.S.U. Chowdhury, M. Saha, M.T. Islam, "Heat transfer and friction factor characteristics in turbulent flow through a tube fitted with perforated twisted tape inserts", *International Communications in Heat and Mass Transfer*, Vol. 46, 2013, pp. 49-57..
- [5]. Panida Seemawute, Smith Eiamsa-Ard, "Visualization of Flow and Heat Transfer in Tube with Twisted Tape Consisting of Alternate Axis". 4th International Conference on Computer Modelling and Simulation (ICCMS 2012) IPCSIT vol.22 (2012) © (2012) IACSIT Press, Singapore.
- [6]. Likhendra, Prasad., Hakeem, Niyas., Muthukumar, P., 2013, "Performance Analysis of High Temperature Sensible Heat Storage System during Charging and Discharging Cycles", 4th International Conference on Advances in Energy Research 278, pp. 1240-1247.

- [7]. Ezhilarasu, M., Krishnan, A.S., 2013, "Experimental and Computational Studies on Transient Heat Transfer and Fluid Flow in a Packed Bed", Proceedings of 13th UK Heat Transfer Conference, UKHTC2013/199, pp. 1-8.
- [8]. Gokul, M., Krishnan, A.S., 2015, "Comparative Studies on Heat Transfer and Fluid Flow in Cored Brick and Pebble Bed Heaters", International Journal of Research in Engineering and Technology, eISSN: 2319-11.
- [9]. Dutta, P., and Hossain, A., "Internal cooling augmentation in rectangular channel using two inclined baffles", International Journal of Heat and fluid flow, Vol. 26, pp. 223-232, 2005.

## BIOGRAPHY



BAKHIRATHAN A has obtained his M.E. – Heat Power Engineering from Coimbatore Institute of Technology, Coimbatore, India (2017) and his B.E. degree in Mechanical Engineering from PSNA College of engineering and technology, Dindigul, India in 2014. His areas of interest are Thermal science and Fluid mechanics etc.