

RURAL ELECTRIFICATION-SOLAR WAY

Nanda Shivamoggi¹, Nagaraj Hediya²

¹Assistant Professor, Sir M.Visvesvaraya Institute of Technology, Bangalore, Karnataka, India

²Chief Executive Officer, M/s eNLiven Technologies, Bangalore, Karnataka, India

Abstract

Electricity is an essential requirement for all facets of our life and it has been recognized as a basic human need. It is the key to accelerating economic growth, generation of employment, elimination of poverty and human development especially in rural areas. Rural Electrification (RE) is viewed as the key for accelerating rural development. Provision of electricity is essential to cater for requirements of agriculture and other important activities including small & medium industries, khadi, village industries, cold chains, health care education and information technology. The Renewable energy is the only promising solution to meet the growing demand of electricity services of rural household's located remotely. Micro Wind, Pico Hydro and Solar Photovoltaic (SPV) can be considered as reliable and promising renewable systems to cater to the needs of the rural electrification. Solar photovoltaic technology-based applications, especially, solar lighting is viewed as a viable option for rural, semi-urban, and urban lighting need for home, community areas, and streets. The paper proposes Solar Photovoltaic System Scheme to provide the electricity to the remote, isolated rural households. The proposed scheme is justified in terms of its applicability, suitability, technically, and economically.

Keywords: Renewable Energy, Micro Wind, Pico Hydro, Solar Photovoltaic, System, Home Lighting, Rural, Remote.

-----***-----

1. INTRODUCTION

Rural Development in India is one of the most important factors for the growth of the Indian economy. Since India is primarily an agriculture based country, the village empowerment plays an important role in the development. Rural development in India has witnessed several changes over the years in its emphasis, approaches, strategies and programs. It has assumed a new dimension and perspectives as a consequence. Rural development can be richer and more meaningful only through the participation of clientele of development. Rural development aims at improving rural people livelihoods in an equitable and sustainable manner, both socially and environmentally, through better access to assets (natural, physical, human, technological and social capital), and services.

The basic objectives of Rural Development Programmes have been alleviation of poverty and unemployment through creation of basic social and economic infrastructure, provision of training to rural unemployed youth and providing employment to marginal Farmers/Labourers to discourage seasonal and permanent migration to urban areas.

According to census 2011 [1], 14.3% of rural population doesn't have any assets such as house, cattle, agriculture land etc in Karnataka. Housing constitutes a very basic requirement for human survival. It assumes great significance for the rural poor in that it lays the foundation for a life of dignity for them by dispelling the gloom of shelterlessness and conferring a distinct, secure identity. Addressing housing shortage is thus an important strategy of poverty alleviation in India. Similarly, as per statistics 11, 64,584 households do not have access to power. Out of this

2, 66,824 are in urban and 8, 97,760 in rural areas. Further, 104,963,972 households in rural area still depend on fire wood for cooking exposing rural women to severe kitchen indoor pollution affecting their health adversely.

Green initiative is considered to be the most challenging and essential topic today due to the alarming rate of rise of emission level. The impact and the effect of emission are such that the human is facing tremendous challenges in all his walk of life. The major contributors for the environmental degradation are vehicles, industries, mismanagement of wastages etc. There is a tremendous amount of research work under taken to find the solution to pollution control [2]. Since the major sources of electricity are using fossil fuels which are nonrenewable in nature. These are not only producing large amount of waste but also contributing to the environmental degradation while generating as well as utilizing the electricity.

As brought discussed in [3], the fast depletion of fossil fuels, exponential increase in demand, global warming, emission of CO and CO₂ made engineers and scientists to look for an alternative source of energy which is renewable, eco-friendly, affordable and available. Among the renewable sources like wind, tidal, geothermal and solar energy, solar power is promising in nations like India which is in the tropical region.

Olawale Saheed Ismail *et al* [4] have shown that the lack of technical know-how and inadequate training as well as ill-experience of the project managers is also a cause for the worry. There is a strong belief that the efficiency and performance of installed solar PV systems will be of great importance, which has to be considered and studied in depth. Solar PV systems will become a beacon for reliable

power source in villages with no access to national grid. It has been clearly studied and presented by F.D.J.Nieuwenhout et al [5], though the solar energy is widely perceived as a promising technology for electricity generation in remote locations, but the financial, technical and organizational problems have pointing towards the effectiveness and suitability of SPV systems for rural development.

A sufficiently high quality of solar photovoltaic system components is essential for a successful introduction of solar electricity for household applications. Frequent failures, even of small and cheap components as fluorescent tubes will cause user-dissatisfaction that will quickly lead to reduced incentives to continue repaying the fees if the system was not sold for cash. Well-designed systems with sufficient product quality are essential to make systems financially viable.

Solar photovoltaic technology-based applications, especially, solar lighting is viewed as a viable option for rural, semi-urban, and urban lighting need for home, community areas, and streets. This paper aims to describe the suitability and the reason for considering the Solar Photovoltaic System for Home lighting applications of Rural Electrification. Hence, the testing, benchmarking, validation and quality assurance is thus the need of the hour.

2. WHY SOLAR ENERGY?

The biggest challenge of the energy requirement worldwide has become a Terawatt Dilemma as indicated by the survey undertaken in the year 2007 and is depicted in figure-1 below.

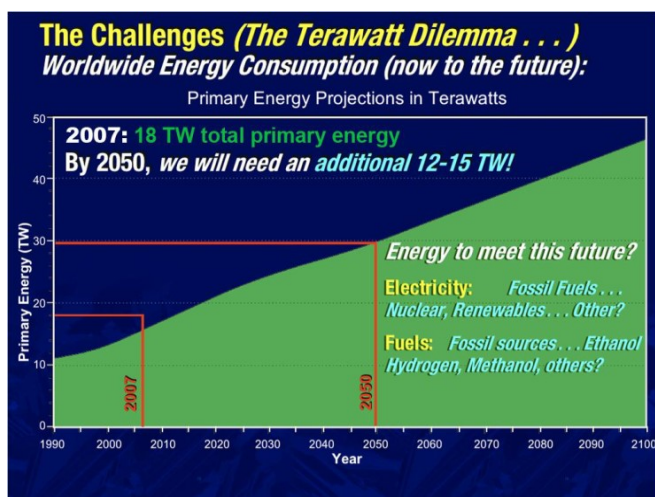

Fig 1: Terawatt dilemma.

The demand for the electricity is much higher than the generation. This is a big challenge for the development of the country in terms of economy and growth. For the developing countries like India energy demand becomes much more important and bigger challenges in terms of strong economy, national security and sustainable development.

The present power scenario of India, as per Ministry of New Renewable Energy (MNRE) is as shown in figure 2 below:

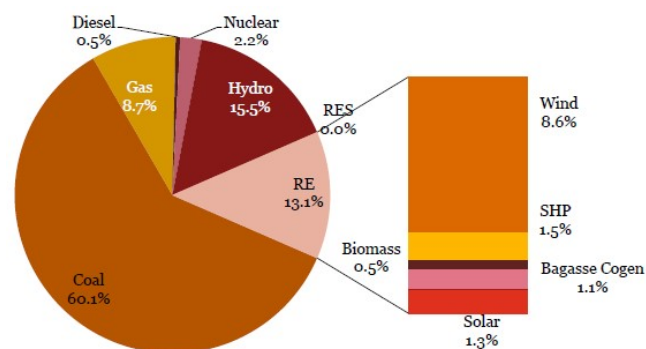

Fig 2: Present Scenario of Power in India

Most of the power demand in India is based on fossil fuel based i.e, using Coal 60.1%, Gas 8.7%, Nuclear 2.2%, Diesel 0.5%, Hydro 15.5% and RE 13.1%. The energy requirement is expected to increase by 200% from FY15 to FY30. As per energy statistics 2015, the potential for renewable energy is as shown in figure-3 below:

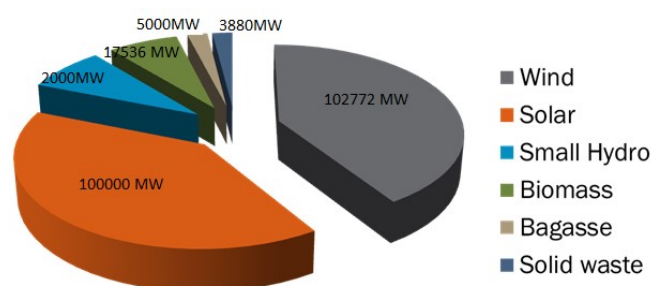

Fig 3: India-Total Potential Renewable Energy in MW.

Since the present energy generating sources are depleting very fast than thought, & may not last for long. The demand vs supply is a major concern as seen above; the only answer to this problem is renewable resources. An adequate and reliable power supply system is essential for any developing country like India. As on date, Photovoltaic (PV) technology is one of several renewable energy technologies, adopted globally in meeting basic electricity needs for rural areas which are deprived of grid. RSPV are the viable alternatives for reliable sources of energy for small loads in remote areas and rural communities.

3. SOLAR PHOTOVOLTAIC SYSTEM

Photovoltaic conversion is the direct conversion of sunlight into electricity with no intervening heat engine. Photovoltaic devices are solid state; therefore, they are rugged and simple in design and require very little maintenance. Perhaps the biggest advantage of solar photovoltaic devices is that they can be constructed as standalone systems to give outputs from microwatts to megawatts. That is why they have been used as the power sources for calculators, watches, water pumps, remote buildings, communications, satellites and space vehicles, and even megawatt-scale power plants.

3.1 The PV Cell

PV cells have been made with silicon (Si), gallium arsenide (GaAs), copper indium diselenide (CIS), cadmium telluride (CdTe), and a few other materials. The common denominator of PV cells is that a p-n junction, or the equivalent, such as a Schottky junction, is needed to enable the photovoltaic effect. The pn Junction and the PV cell are shown in figure 4 (a) and 4 (b).

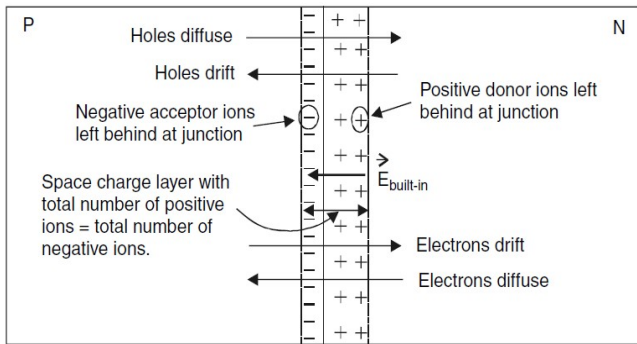

Fig-4 (a) pn Junction

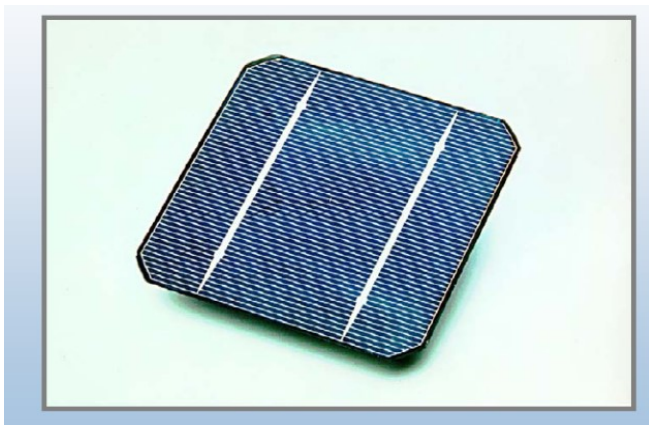

Fig-4 (b) PV Cell

3.2 I-V Characteristics of Solar Cell

The solar cell exhibits certain characteristics of definite nature as shown in fig -5 and figure-6.

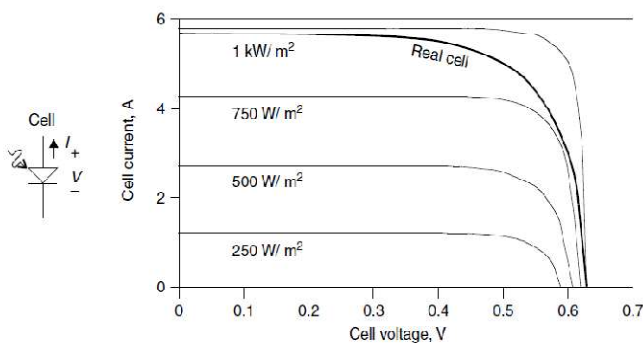

Fig 5: I-V Characteristics of real-ideal PV cells under different illumination levels.

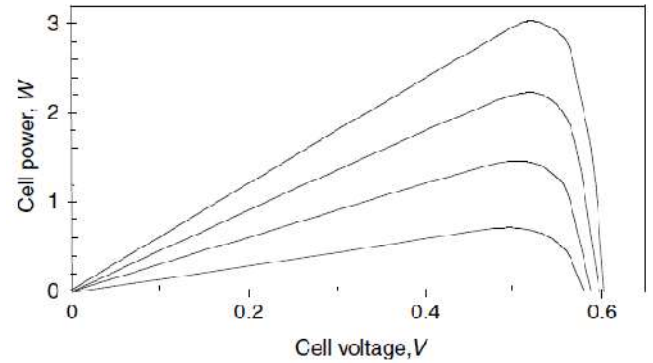

Fig 6: Power vs Voltage for a PV cell for four illumination levels.

3.3 RSPV Systems

Possible roof top solar photovoltaic configurations are shown in figure-7 (a), (b), (c) and (d).

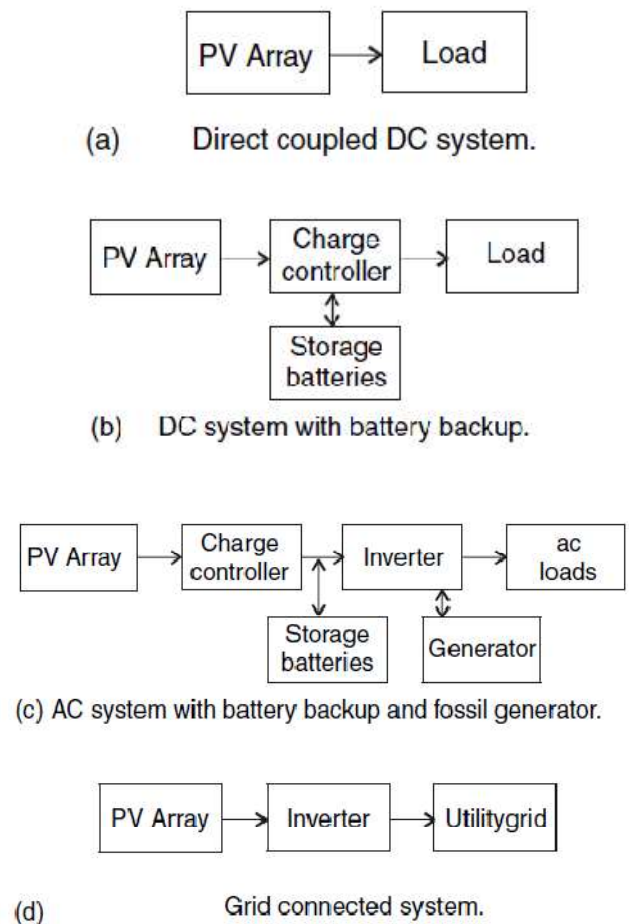

Fig 7: RSPV Configurations

The system shown in figure 7 (a) is the simplest and solar panel directly feeds the load. The system shown in figure 7 (b) has charge controller and storage batteries so that PV array can produce energy during the day that can be used day and night by the load. The charge controller serves a dual function. If the load does not use all the energy produced by the PV array, the charge controller prevents the batteries from over charge. The configuration in 7 (c)

consists of inverter which converts DC to AC and supplies AC loads. Whereas the configuration 7(d) is a grid connected system. If grid is inactive then the whole system is inactive even though solar panel produces output.

4. PROPOSED SCHEME OF RURAL ELECTRIFICATION

This paper proposes a solar photovoltaic DC system with battery backup to provide lighting to the rural households. The envisaged system is a small and compact with expectations to meet the objective of Rural electrification. The proposed system has been studied in detail in terms of its configuration, reliability, viability, durability etc.

4.1 System Configuration

The proposed system configuration is very simple as shown in figure 7 (b) in the previous paragraphs. It consists of a solar photovoltaic array generally known as Solar panel, Charge controller to regulate the energy, battery to store the energy and load, as represented in configuration.

Solar Panel	20W Polycrystalline
Battery	12V, 7.5Ah, C10
Charge Controller	24V, 5A
Mobile Port	5W x 1
Luminaries	5W x 2

4.2 Load Calculation Example

Let us assume the load structure of a typical rural household having a kitchen and living rooms to be as listed below:

Table-1: Load of a typical rural house hold

Sl No	Rooms	Appliance	Hrs/Day	Wh/Day
1	Kitchen	LED 5W	1.5	7.5
2	Living	LED 5W	2	10
3	Mobile port	5W	1	05
Total Whr/day				22.5

The total energy requirement as per the load profile specified in Table-1 above is about 30Whr. Assuming the 2 days autonomy the total demand for energy is about 22.5 * 2 = 45 Whr/Day.

4.3 Solar Photovoltaic System Sizing

4.3.1 Energy Demand

Total energy demand is about 45Whr with two days autonomy.

$$(5W \times 1.5) + (5W \times 2) + (5W \times 1) = 22.5Whr/Day.$$

$$\text{With two days autonomy} = 22.5 \times 2 = 45Whr$$

4.3.2 Battery Sizing

$$\text{Battery Capacity} = \frac{45 \text{ Whr}}{12 \times 0.85 \times 0.6} = 7.8125Ah$$

Where:

- The factor 0.85 is to cater for battery losses.
- The factor 0.6 is for the depth of discharge of battery.
- The total Ampere –hours required 7.8125 Ah.

So the battery should be rated 12V 7.5Ah which is near to a standard battery rating. The battery needs 750mA for charging with C10 rating.

A 12V, 7.5 Ah battery can suffice the requirement. Having considered the battery of capacity 12V, 7.5Ah the minimum current required for charging the battery is about 750mA with C10 rating.

4.3.3 Photovoltaic Panel Sizing

- Total PV panel energy required = (45)x(1.3) =58.5 Whr
Where 1.3 is factor of safety to take care of energy lost in the system.
- Total Wp of PV panel = $\frac{58.5}{4} = 14.625Wp$
In this design a 20Wp solar panel is chosen which is nearest to the calculation and provides required charging current to the battery.
Open circuit voltage= 21.67V
Short circuit current =1.36A
Maximum Voltage = 17.72V
Maximum current= 1.12A

Therefore a normal charge controller with low voltage disconnect, over charging control, features is designed. The charge controller is designed such that the load is disconnected when battery voltage falls below 10.8V and load reconnected when battery voltage charges to 11.8V. Another feature is that the charge controller has an option of completely stopping the charging process when battery reaches 14.4V and also trickle charging at 13.8V if required. The solar panel required is 20Wp which provides about 1.12A maximum current. The open circuit voltage of the panel is about 21.67V, and short circuit current is about 1.36A. Designed solar charge controller, battery and solar panels are connected shown in figure-8 (a), Charge controller separately 8 (b) and figure-8 (c) LED light of 5W.



Fig-8 (a): Charge controller, Battery and Solar panel

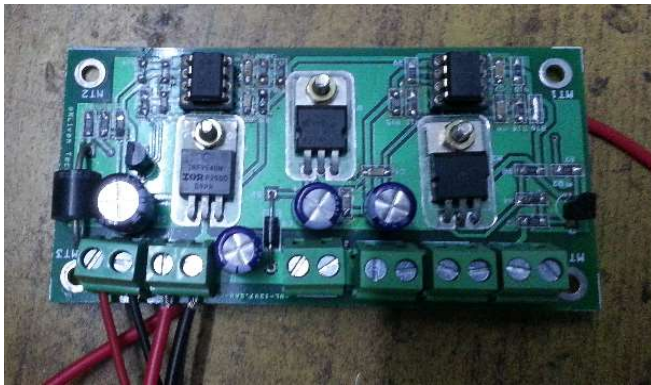

Fig 8 (b): Charge controller



Fig 8 (c): 5W LED Bulb

Battery is of capacity 12V, 7.2Ah with C10 charging rate. It is a maintenance free battery. The charge controller is designed to regulate the voltage and current of the panel while charging the battery. It has a low voltage disconnect facility and trickle charging option as well. It has a mobile charging port.

4.4 Cost Implications

Solar Panel 20Wp	INR: 1000
Battery 12V, 7.5Ah C10	INR: 1200
Charge controller	INR: 1250
9W LED bulb x 2	INR: 0650
5W LED bulb x 2	INR: 0500
Miscellaneous	INR: 0850
Total cost (DC Type)	INR: 5450/-

The designed system is DC type, special care is ensured while wiring the system and testing.

4.5 Test Results and Analysis

1. Solar panel was tested for its performance and found satisfactory with irradiance of 1230 KWH/m². The performance characteristics such as V-I and P-V curves have followed the ideal curves. They are shown in figure 9 (a) and 9 (b).

Volts (V)	Current (I)
0	1.27
16	1.25
16.6	1.2
17.2	1.15
18	1
18.92	0.95
19.6	0.8
20.5	0.71
20.9	0.65
21.2	0.58
21.4	0.4
21.44	0

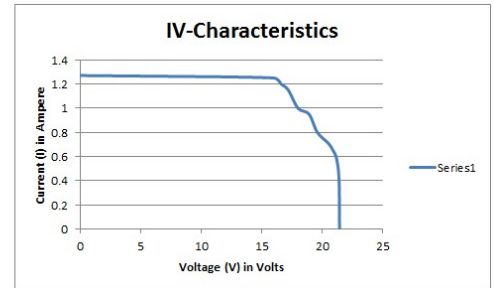

Fig 9 (a): VI-Characteristics of PV module

Volts (V)	Power (P)
0	0
16	20
16.6	19.92
17.2	19.78
18	18
18.92	17.974
19.6	15.68
20.5	14.555
20.9	13.585
21.2	12.296
21.4	8.56
21.44	0

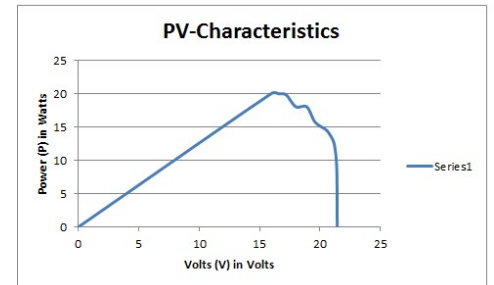

Fig 9 (b) PV-Characteristics of PV module

- The battery was tested for its charging time and found that with the selected panel the time taken to charge the completely discharged battery is about 11hrs 30 min approximately.
- Battery was discharged @ 0.17C for 4.5hrs with a load pattern in Table-1 above. The autonomy of the system found to be 2 days. The discharge curve of the battery is shown in figure-10.

Volts (V)	Time (hrs)
12.65	0
12.61	0.25
12.45	0.5
12.31	0.75
12.27	1
12.12	1.25
12.05	1.5
11.95	1.75
11.82	2
11.73	2.25
11.67	2.5
11.58	2.75
11.36	3
11.04	3.25
10.91	3.5
10.8	3.75

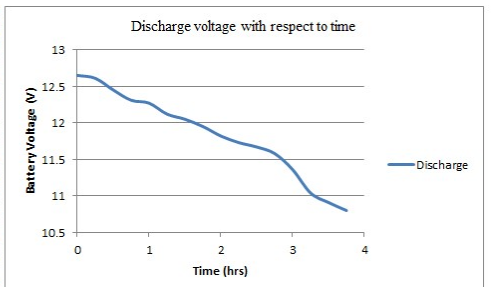

Fig 10: Discharge Curve of battery

- Charge controller was tested in different operation mode such is simple ON/OFF mode while charging and discharging the battery along with load. Also tested for float mode by taking into account the load disconnect /reconnect, Battery charging and entering into float on complete charging of the battery.
- Selected luminaries have been tested for their efficacy and brightness. Their performance found satisfactory.

5. CONCLUSION

In this paper, design and development of solar photovoltaic system for home lighting application was carried out. The system designed is well suited for rural house hold and would definitely serve the purpose meeting the lighting

needs of rural population as far as its performance is concerned. Moreover the cost of the system is very low. The system is very much affordable by the below poverty line households. The biggest advantage of such systems that they meet the lighting needs without the grid. It is an off grid system with mobile charging port.

REFERENCES

- [1] CENSUS of India 2011, "House, Household Amenities & Assets"
- [2] Nagaraj Hediya and Sujatha Nagaraj "Efficient Speed Governor for Blower Motor", International Journal of Research in Engineering and Technology (IJRET) eISSN: 2319-1163/ pISSN: 2321-7308 Volume: 03 Issue: 02/ Feb-2014, pages 334-338, Available @ <http://www.ijret.org>.
- [3] RajendraBeedu "Design, development and performance evaluation of Solar power assisted Tricycle" IJRET: International Journal of Research in Engineering and Technology eISSN: 2319-1163 | pISSN: 2321-7308.
- [4] OlawaleSaheed Ismail, Olusegun Olufemi Ajide, Fredrick Akingbesote "Performance Assessment of Installed Solar PV System: A Case Study of Oke-Agunla in Nigeria", *Scientific Research Engineering*, 2012, 4, 453-458.
- [5] F.D.J. nieuwenhout et al "Experience with Solar Home Systems in Developing Countries: A Review", *Progress in Photovoltaics: Research and Applications*, prog. Photovolt: Res. appl, 2001; 9: 455-474 (DOI: 10.1002/pip.392)
- [6] Kumaresh.V, Mridul Malhotra, Ramakrishna N and Saravana Prabu.R "Literature Review on Solar MPPT Systems" *Advance in Electronic and Electric Engineering*, ISSN 2231-1297, Volume 4, Number 3 (2014), pp. 285-296
- [7] Chonmapat Torasa "The Evaluation of Electricity Generation and Consumption from Solar Generator: A Case Study at Rajabhat Suan Sunandha's Learning Center in Samutsongkram" *International Journal of Electrical, Computer, Energetic, Electronic and Communication Engineering* Vol:8, No:4, 2014

Energy Conservation) at Mahatma Gandhi Institute of Rural Energy & Development, Govt of Karnataka undertaking Bangalore for a brief period. He served as Vice President-Technical, leading R & D and Production divisions at Systems Aids Bangalore-43. Formerly, Technical Manager, CG-CoreEl Programmable Solutions Pvt Ltd, Bangalore. He served as Head of the Section (Encryption) & Scientist, Core R & D, ITI Ltd, Bangalore-16. He was the main & leading designer of most of the encryption systems at ITI Ltd. The advanced high speed STM1, STM4 and E3 ATM encryption systems were his brain child's to name a few. He has authored and co-authored number of proprietary encryption algorithms for Indian Defence networks used by Army, Navy and Air-force. He was honoured with letter of appreciations from both ITI Ltd and Indian Army. He is a fellow of IETE and Life member of CRSI. His research interests are Cryptography, VLSI, Industrial Electronics, Renewable Energy and Embedded Systems.

BIOGRAPHIES



Mrs. Nanda M. Shivamoggi received her BE, and M.Tech from Karnataka University and VTU Belgaum. She has over 30 years of experience in academic and industrial. She is currently serving as Assistant Professor in the Department of Electrical and Electronics, Sir MVIT Bengaluru. Her research interests are Power Electronics, Electrical Machines and Renewable Energy systems.



Nagaraj Hediya received his BE (EE) and M.Tech (CAID) from Bangalore University and VTU Belgaum respectively. Currently he is a Chief executive Officer at M/s eNLiven Technologies. He was Additional Director and HOD (Renewable Energy &