

BEHAVIOUR AND ROUTING SYSTEM FOR MOBILE AGENT WITH NAVIGATION OF MOBILE ROBOT IN CLUTTERED ENVIRONMENT

Amandeep Walia¹

¹Automation & Robotics, Ambalika Institute of Management & Technology, Lucknow

Abstract

Now a day's mobile robots are widely used in many applications. Navigation of mobile robot is primary issue in robotic research field. The mobile robots to be successful, they must quickly and robustly perform useful tasks in a complex, dynamic, known and unknown surrounding.

Keywords—Mobile Robot, Navigation, Fuzzy Logic

1. INTRODUCTION

“A Robot is reprogrammable, multi purposeful manipulator premeditated to be in motion material, parts, tools or specific plans through unpredictable programmed motions for the presentation of a variety of tasks.”

According to application of mobile robot, capability to navigate in the environment is essential. Navigation defined as the process of directing the movement of a vehicle from one point to another with the help of types of sensors to the different environment like indoor, outdoor and cluttered by using the various navigation techniques such as artificial intelligence.

Robot navigation is nothing but the mobile robot's capability to decide its own location and then to map a path towards target location. Track planning is efficiently the addition of localization

And it wants the resolving the robot present condition and a target place and together within the identical coordinates.



Fig1: Mobile robot with arm manipulator

Robots are used in almost every application related to industry where repetitive and complex tasks are involved and task which is very dangerous or cannot do the manually such as

- Painting the car, Welding the different specimen or machine and surface finishing in the aerospace and automobile industries
- submarine and space application
- Destructive fritter away remediation in administration labs, nuclear services and medicinal labs
- Examination of parts
- Electronic and consumer products assembly
- Inspection and dispatching parts in various industries

Obstacle avoidance is the primary requirement for any autonomous robot. The major challenge in the field of Autonomous Ground Vehicles (AGVs) is navigation of the robot in environments that are closely in a mess with the obstacles. The controlling of mobile robot becomes more complex when the arrangement of obstacles not known.

Navigation Types

The navigation problem in cluttered environment divided into two parts that is:

- (1) Speed control
- (2) Heading control

The speed control uses two characteristics:

- (1) Avoid the obstacles and
- (2) Overturning avoidance.

The heading control done by four characteristics:

- (1) Avoid the obstacle on front side
- (2) Avoid the obstacle on right side
- (3) Avoid the obstacle on left side
- (4) Target seeking.

Each one of these characteristics uses the information from sensors and find out its remedies and action.

2. FUZZY LOGIC

Fuzzy controller technique with image processing technique using Open Source Computer Vision presented by Gonzales [1]. Fuzzy logic used for managing the navigation of robot directing towards the destination with obstacles avoidance with the help of changing the direction and movement of the mobile robot. Image processing technique is used to gathering the information of the environment.

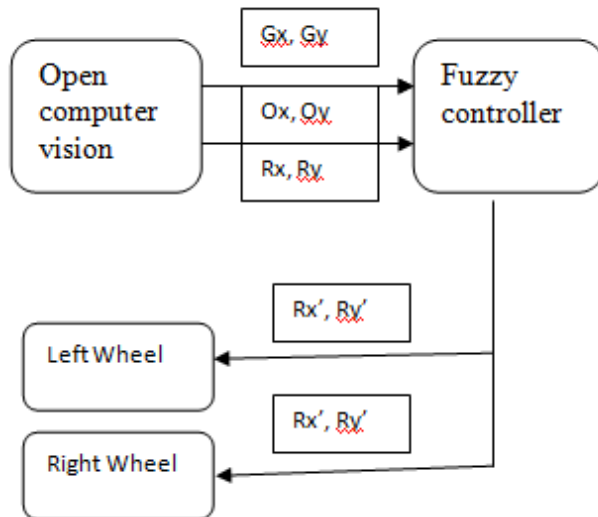

Fig2: Open source Computer vision using Fuzzy controller

Where,

G_x, G_y - Position of Robot

O_x, O_y - Obstacles

R_x, R_y - Destination

Navigation of mobile robot in disorderly environment by predilection based fuzzy behaviors Presented by Dunlap et al. [2]. In this, they solve the problem of navigation of autonomous ground vehicle.

In this they gives the information from sensor that is ultrasonic sensors used for calculating the distances of the obstacles around mobile robot and infrared sensor used for detecting the behavior of the destination.

3. ROBOT KINEMATICS:

It is defined as the association of multi degree freedom of kinematic chains which forming the configuration of the robotic system. In this, various links are interconnected and forming the geometry and the study of such geometry considered in the robot kinematics .

For controlling the movement of mobile robots, we require:

- Kinematic or dynamic model of robots.
- Model of interaction between wheel and the robot.
- Definition of the required motion.
- Speed and Position control.
- Control law that satisfied the requirements.

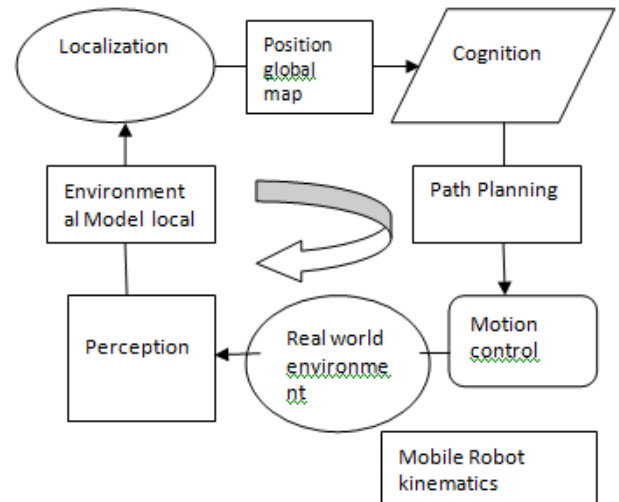

Fig 3: Control Mechanism for mobile robot navigation

Modern Applications of Robot

- A greenhouse is a building in which plants are grown.
- Today, agriculture constitutes one of the most important sectors under development in many areas of the world.
- Ultrasonic sensor gives the simple way and efficient methodology for the distance measurement.
- Digital Compass used to detect the heading of mobile robots. UVTRON Flame Sensor is well suited for use in flame detector and fire alarm.

4. PARTICLE SWARM OPTIMIZATION (PSO)

A Geese particle swarm optimization integrated with fuzzy controller for Extended Kalman filter based answers of concurrent localization and mapping problems in robot Presented by Chatterjee et al.[20]. In this they planned a effective execution of newly planned change to Particle Swarm Optimization algorithm which is nothing but Geese Particle Swarm ptimization algorithm, to integrate the parameter of the supervisor, in use for the Extended Kalman filter method for finding out the simultaneous localization and mapping troubles of robots. This technique is mainly appropriate for the process uncertainty related with Extended Kalman filter based simultaneous localization and mapping move towards unknown or wrongly known.

5. ANT COLONY OPTIMIZATION (ACO)

Track preparation for mobile robot navigation with ACO and fuzzy cost task evaluation Presented by Garcia et al. [28].They gives a proposal to find out the solution of track planning for the robots which is depend on Ant Colony Optimization Meta-Heuristic. In this method for "SACOd_m", d symbol is using for distance and m symbol for memory. In this, the judgment creation procedure is affected by present gap in the source and destination nodes furthermore the ants remembering the visiting positions.

Ant Colony Optimization (ACO) and Particle Swarm Optimization (PSO)

In this ACO used for plan the track for mobile robot transit able territory, and PSO used for enhancing the constraints of ACO.

In this PSO is used for optimize the ACO and with the help of this mixed algorithm we can calculate the navigation difficulty of self-governing mobile robot.

6. FUTURE FRAMEWORK

- In this project work, the AI techniques developed for path planning analysis of mobile robot enable the robots to avoid hitting among each other and with static obstacles. However, future development of the techniques may require for avoidance of dynamic obstacles other than static obstacles.
- Multiple mobile robots with multiple targets are considered instead of single mobile robot with single target.

7. CONCLUSION

Where the human being cannot work properly and different obstacles are present then with the help of mobile robot, work can be done easily. In the current research, different environments are considered to find out the navigation path for the mobile robot. The structure of the kinematic models of various types of wheeled mobile robots is also studied. The simulation is done by writing the code in MATLAB in different environment scenarios while avoiding obstacles present on the robot path. The success of the robot navigation depends upon the accuracy of complete measurements of positions (mobile robot, obstacles and destination point), velocities (or speeds of mobile robot) and its rate of change of heading angle (of a mobile robot).

In this, we use fuzzy logic technique (FIS) for navigation of an autonomous mobile robot in an unknown environment. The simulation results showed that the proposed method enables the mobile robot to reach safely the destination (or goal) without colliding the obstacles.

Experiments are also carried on lab build mobile robot. Comparison between the simulation and experimental results is done for establishing the authenticity of the technique developed. The mobile robot along with the technique can be used in different remote and hazardous applications.

ACKNOWLEDGMENTS

I would like to thank my supervisor **Prof. Kamlesh Singh** for his guidance, advice and constant support throughout my thesis work here in Ambalika Institute Of Management And Technology Lucknow.

I am highly grateful to all the faculty members and staff of the Department of Automation And Robotics, A.I.M.T Lucknow for their unforgotten teaching and motivation in my research work.

I would like to thank all my friends, lab mates .

I express my sincere gratitude to all the faculty members of Department of Automation and Robotics, AIMT Lucknow for their affection and support.

REFERENCES

- [1]. Fuzzy controller technique with image processing technique using Open Source Computer Vision, "Jurlirose Gonzales, ZahariTaha", Journal of advanced computational intelligence, Vol. 12, Nov. 4,2008.
- [2]. Robot navigation in very cluttered environment by preference based fuzzy behaviors, "Majura S. Selekw, Damion D. Dunlap, Dongqing Shi., Emmanuel G. Collins Jr."Volume 56, 31 March 2008 ,Robotics and Autonomous Systems
- [3]. Fuzzy logic-based real-time robot navigation in unknown environment with dead ends, "Meng Wang, James N.K. Liu", Volume 56, Issue 7, 31 July 2008, Department of Computing, The Hong Kong Polytechnic University, Hung Hom, Hong Kong.
- [4]. Fuzzy logic techniques for navigation of several mobile robots,"Saroj Kumar Pradhan,DayalRamakrushnaParhi , Anup Kumar Panda",Volume 9, Issue 1,Applied Soft Computing January 2009,