

WIRELESS DATA TRANSFER USING VISIBLE LIGHT COMMUNICATION

Liju Sajan¹, Lince Mathew², Abraham Thomas³, Sarun Sathyan⁴, Bibin Baby⁵

¹Student, Dept. of Electronics & communication, BTC College of Engineering, Koothattukulam, Kerala

²Assistant Professor, Dept. of Electronics & communication, BTC College of Engineering, Koothattukulam, Kerala

³Student, Dept. of Electronics & communication, BTC College of Engineering, Koothattukulam, Kerala

⁴Student, Dept. of Electronics & communication, BTC College of Engineering, Koothattukulam, Kerala

⁵Student, Dept. of Electronics & communication, BTC College of Engineering, Koothattukulam, Kerala

Abstract

Wi-Fi technology is the most popular technology to connect a network easily. To overcome the speed constraints of Wi-Fi technology, a new technology called Li-Fi was introduced in 2011 by Harald Haas who was a German physicist. Li-Fi technology throws out the optic fiber by sending the data through Light Emitting Diodes, which can perform a transmission of 10 megabits per second. Normally visible light communication is done using LED's, but this work demonstrates the data transfer method using single LASER light and a photodiode by using serial communication. A study on VLC was done and most efficient method has been used. Visible light communication system is more useful in the areas where the radiations and OFC are prohibited.

Keywords: Wireless, data, Data transfer, LiFi, VLC, OFC, LASER

1. INTRODUCTION

Communication is the essential part in the field of electronics and communication. It deals with transfer of data from one place to another place. Communication medium has major role in the successful data transfer and to determine the mode of transmission. There are two modes of transmission; wired and wireless transmission.

In wired transmission, data is transferred through a physical medium or a link whereas no physical link is used in wireless transmission. Both mediums have their own characteristics and advantages. Wireless communication uses the RF source to modulate. But it takes some time. But, if we use a visible light instead of RF wave source, transmission speed can be increased. Light wave communications also should have larger bandwidth. The Li-Fi technology uses visible light for the data transmission as the wireless medium [1]. In Li-Fi technology, the data transmitted by illuminating LED or LASER that varies in intensity faster than the human eye can sense the light. The term Li-Fi is used to label the fast and cheap wireless-communication system, which is the optical version of Wi-Fi [1]. The term was first used in this context by Harald Haas in his TED Global talk on Visible Light Communication. Haas says, "They can be switched on and off faster, which helps for data transmission." To encode data in the light can be done by varying the rate at which the light flicker ON and OFF to give different strings of 1s and 0s. The intensity of the light is modulated so rapidly that human eye can't detect, so the output appears to be constant.

In this work, a LASER is used as the light source or transmitter and photodiode as a receiver in the circuits. For the analysis, we transmit an image from one pc to another

.MATLAB software is used to convert and retrieve the image in the computer.

2. GENERAL DESCRIPTION

2.1 Visible Communication System

The visible light communication (VLC) refers to the communication technology which uses the visible light source as a signal transmitter, the air is used as the transmission medium, and the appropriate photodiode as a signal receiving component [3]. Visible light should be considered as the medium for wireless transmission because it has got few advantages over other standard wireless transmissions. The main advantage is visible light's frequency spectrum bandwidth, which ranges from 430 THz to 750 THz. The bandwidth is much larger than the radio frequency bandwidth, which ranges from 3 kHz to 300 GHz. With a larger bandwidth it is possible to accommodate more users and potentially achieve higher transfer rates because each one can give a larger portion of the bandwidth to transfer the information. The abundance is one of the other reasons. Light sources are everywhere, and can be more efficiently used by increasing its simultaneous functionality by transmitting data in addition to lighting to a specific area. On working days, company buildings, restaurants etc. will have lights on for at least the duration of hours of operation, of which is used for VLC[5]. TABLE 1 shows the characteristics of VLC over RF communication.

2.2 Communication using RS 232 Serial Port

Data transfer within a system is generally in parallel. All the bits of the data were transferred in parallel at the same instant from a digital system. In some cases, particularly in transferring data over long distances, it is preferred to transfer the data in serial form. The data word from a transmitting system is converted to stream of serial bits, and one bit is transferred on a single line to a receiving system at a time. At the receiving end, the data is reconstructed by serial to parallel conversion. The speed of data transmission in serial communication is specified by baud rates. Asynchronous data transfer is used for the serial communication which is done at a lower speed, typically at standard rates such as 2400, 4800, 9600, 19200 baud etc. The synchronising clock or timing signal are not used in the asynchronous communication [6].

2.3 LASER Light Communication System

LASER Communication is one of the fast growing area in wireless communication system. Due to its low noise ratio makes it more preferable communication medium for exchange of information. Currently LASER communication is used in satellite communication for space research because of its efficiency on low noise ratio, inexpensive, low power and its flexibility and the LASER communication doesn't affect the radio noises. It made the LASER communication more preferable. In this process, this paper deals with one such application of LASER communication for information exchange between any two devices.

Table 1: Characteristics of VLC over RF communication

Property	VLC	RF
Bandwidth	Unlimited, 400nm~700nm	Regulatory, BW Limited
EMI	No	High
Line of Sight	Yes	No
Standard	Beginning (IG-VLC)	Matured
Hazard	No	Yes
Mobile To Mobile	Visibility (Security) Power Consumption Distance	No Medium Medium
Infra to Mobile	Visibility (Security) Infra Mobility Coverage	No Access Point Yes Wide
	LED Illumination Limited Narrow	

3. PROCEDURE

The main objective of this work is to perform the data transfer to a maximum distance. For conducting this experiment; a 650 nm 5V red dot LASER diode and a silicon photodiode are used as transmitter and receiver. For the proper analysis of this work, we transmit a color image using a software called MATLAB.

3.1 Basic Block Description

The circuit used for data transfer using visible light communication is mainly consist of three sections. They are

1. Power Supply section.
2. Transmitter section.
3. Receiver section.

The FIGURE 1 shows the basic block diagram of the circuit which is used as the data transmitter.

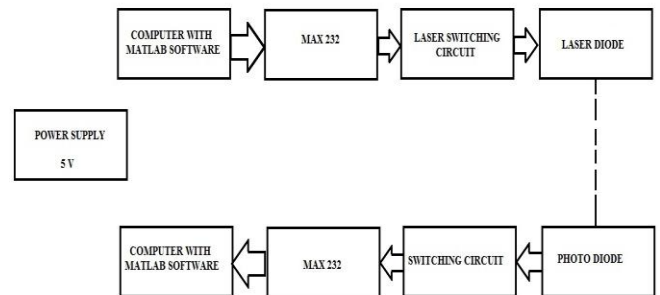

Fig 1: Basic Block Diagram of the experiment

3.1.1 Power Supply Section

Both the transmitter and the receiver section is operated in 5V DC. It is designed using the 7805 regulating IC. The FIGURE 2 shows the power supply circuit diagram. 1N4007 diode is used to make the bridge rectifier. The 780x series of fixed-voltage integrated-circuit voltage regulators are designed for a wide range of applications. These applications are regulation, elimination of noise and the distribution problems associated with single-point regulation. Each of these regulators can deliver up to 1.5 A of output current. The internal current-limiting and thermal-shutdown features of these regulators make them immune to overload. In addition to use as fixed-voltage regulators, these devices can be used with external components to obtain adjusted output voltages and currents, and also can be used as the power-pass element in precision regulators

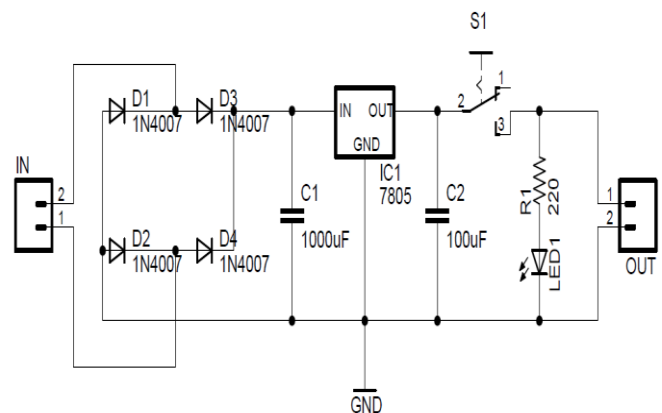

Fig 2: power supply used for transmitter and receiver

3.1.2 Transmitter Section

The transmitter section is used for transmitting image data from the transmitter PC. It consists of several components. They are

- Computer with a MATLAB software
- Max 232 IC
- LASER switching circuit
- LASER diode

The main component in a transmitter section is the visible light source. The LASER is used as the light source to transmit the data transmission is performed using the serial communication technique of the computer. The serial port communication is performed to and fro using the RS 232 pin. For the easy and proper analysis we transmitted an image from one PC to another. For the easy processing and manipulation of the image a software called MATLAB was used. LASER light is the main component in the transmitter section. Here a Normal a 650 nm 5V red dot LASER diode is used to transfer the data. In this study the data is changed to binary by using the MATLAB software and then transmitted. The output of the computer is taken using the serial communication port. As the modern computers and laptops have a serial output port, here used a USB to Serial port converter. The output of the computer is made to a constant output by using a MAX 232 IC. While the LASER is in ON condition, it's considered to be as 1 at the receiving end else 0. The driver circuit of the LASER is designed by using a BC 547. The circuit diagram and working is been discussed in next sections.

3.1.3 Receiver Section

The silicon photodiode is used as the receiver. The MAX 232 IC is used to convert the TTL logic to RS 232 logic. So that the computer can process the data.

4. EXPERIMENTAL SETUP

4.1 Transmitter Section

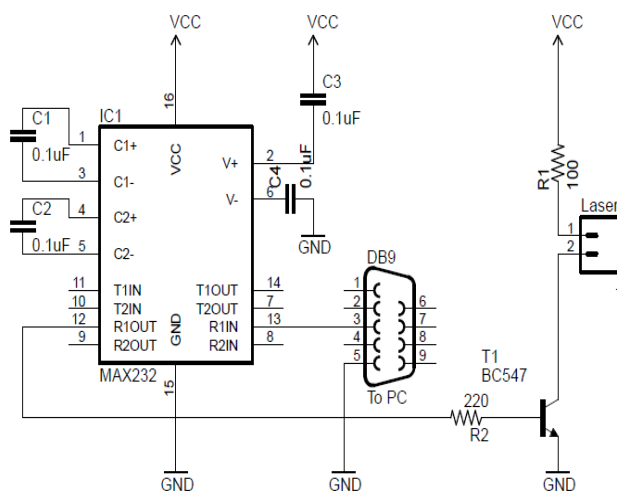

Fig 3: Transmitter Circuit Diagram

Working Principle

In this study, the serial communication is performed to transfer the data. This circuit is mainly consists of Max 232 IC. DB9 Pin receives the data towards the Max 232 IC. MAX 232 IC converts RS 232 logic input to TTL logic output which is used to drive the LASER diode [2]. The data is transferred as binary data. Here the LASER diode is made on and off simultaneously according to the received input using switching circuit made by BC 547. While zero is received, the output of MAX 232 will be 0V, else 5V.

4.2 Receiver Section

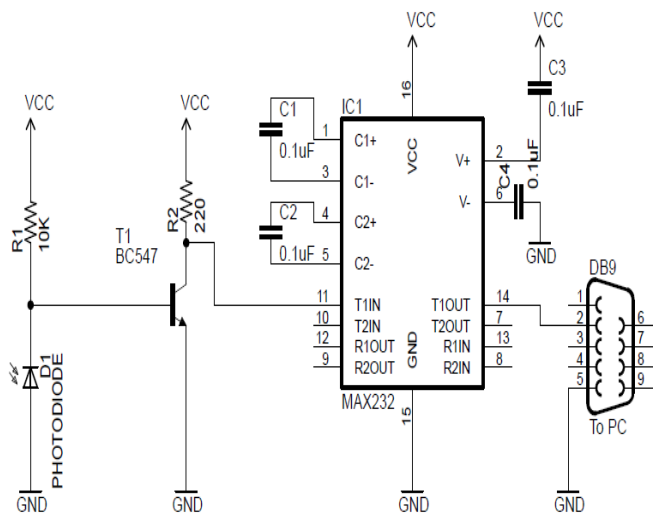

Fig 4: Receiver Circuit Diagram

Working Principle

Photodiode is used as the receiver. The photodiode is directly connected towards the Max 232 IC to retrieve it into RS 232 logic. Then it is directly given to the computer. This input can be processed easily.

5. OBSERVATIONS

The experiment was a perfect success in transmitting the data through the LASER light to a maximum distance. Observations are listed below,

- Data was able to transmit to a distance of 5 meters using this LASER if the transmitter and receiver is in line of sight.
- Can increase the efficiency by changing the parameters such as type of LASER diode and photodiode used.
- As this circuit is not having a modulation scheme, it is very easy to process at the transmitter and receiver.
- Since the transmission and reception command is given manually, were able to transmit the data in baud rate up to 9600. Thus we understood that any kind of data transmission can be performed faster if we create a specific software for transmitter and receiver.

6. OBSERVATIONS FOR CHANGED PARAMETERS

For the analysis of the difference between normal visible light transmission and LASER light transmission, we have tried to transmit the data using a single LED. It was observed that, maximum data transfer was possible up to 3 cms due to scattering of the LED light. The transmission distance can be increased by placing more powerful LASER lights and efficient photoelectric LASER sensors such as bulletin 42 cm 18 mm LASER sensors which will be able to use for industrial applications as well as heavy duties.

7. CONCLUSION

VLC is the trend of today and near future. It is one of the cheapest method of data transmission. Data transfer capable using a LASER light helps to transfer the data to a higher distance without any issues. Data transfer using single LASER light is demonstrated. Serial communication was absorbed and no modulation scheme where. The observations show that LASER light can be used for visible light communication system to transmit the data to a higher extend due to its coherency. An analytic study by changing the LASER with LED lights were done. Based on the observations it is clear that LASER light is more efficient and powerful than LED for the data transmission from one place to another in visible light communication system. The data transferring prototype of visible light communication system has only been verified here. On the basis of the analytic study, we can conclude that LASER is the preferable light source for VLC.

FUTURE APPLICATION

As the data transfer using LASER light is possible without any kind of modulation, this idea can be used in the development of Li-Fi technology by proper design changes in circuits. This method of data transmission can be applied where optic fiber and radiation prohibited areas such as chemical plants. This method can be used for wireless communication such as communication between space shuttles etc. This analytic study can be used for the future development of visible light communication systems. This can be applied at the chemical plants where the RF waves and OFC cannot be used.

LIMITATIONS

The data transfer is only possible if the transmitter and the receiver is in line of sight. The interference such as striking of objects between the transmitter and receiver will causes the data loss.

Use of this photo diode may cause interruptions due to other light sources.

REFERENCES

- [1]. International Journal of Applied Engineering Research, ISSN 0973-4562 Vol.7 No.11 (2012)
- [2]. International Journal of Electronics and Electrical Engineering Vol. 1, No. 4, December, 2013.
- [3]. International Journal of Engineering Trends and Technology (IJETT) – Volume 13 Number 3 – Jul 2014
- [4]. Proceedings of the 1999 IEEE Industry Applications Society Conference Phoenix, Arizona, USA, October 3-7, 1999
- [5]. IEEE JOURNAL ON SELECTED AREAS IN COMMUNICATIONS, VOL. 27, NO. 9, DECEMBER 2009
- [6]. ISSN: 2277-3754 ISO 9001:2008 Certified International Journal of Engineering and Innovative Technology (IJEIT) Volume 3, Issue 12, June 2014
- [7]. Komine and M. Nakagawa, "Fundamental analysis for visible light communication system using LED lights," IEEE Trans. On consumer electronics, vol. 50, pp. 100-107, 2004.