

COMMUNICATION AID WITH HOME AUTOMATION FOR DEAF DUMB

Sudheesh Narayanan¹, Tijomon C. K², Pramod Thankachan³, Vishnu Chandran⁴, Divya M. Kaimal⁵

¹Student, Dept. of Electronics & Communication Engineering, Baselios Thomas I Catholicose College of Engg & Techonology, Koothattukulam, India

²Student, Dept. of Electronics & Communication Engineering, Baselios Thomas I Catholicose College of Engg & Techonology, Koothattukulam, India

³Student, Dept. of Electronics & Communication Engineering, Baselios Thomas I Catholicose College of Engg & Techonology, Koothattukulam, India

⁴Student, Dept. of Electronics & Communication Engineering, Baselios Thomas I Catholicose College of Engg & Techonology, Koothattukulam, India

⁵Assistant Professor Dept. of Electronics & Communication Engineering, Baselios Thomas I Catholicose College of Engg & Techonology, Koothattukulam, India

Abstract

Communications between deaf and dumb people and normal people have been a difficult task. The communication is made possible by the help of an interpreter. This project aims to eliminate the need of an interpreter. It is possible because of the invention of hand-talk glove. Hand-talk gloves come equipped with glue sensors and accelerometer. Flex sensors and accelerometer produces different values for different sign languages used by physically challenged people. A PIC identifies the symbols after processing the sensor values. The output is displayed on LCD display. A text-to-speech converter is also used to convey the message more efficiently.

Keywords: Deaf, dumb, sign language, flex sensor, accelerometer, hand-talk glove.

1. INTRODUCTION

The power of communication can either be a boon or a curse. It helps to awaken thought and expression. The concept of schools and colleges in a way exist because of the ability of human race to communicate. The ability of listening too is of utmost importance. At times GOD play his pranks on humans and steal from him the ability to speak and listen. The so called normal man calls them DEAF AND DUMB. They are normal in all aspects except that they can't communicate like his fellow beings. This inability always makes them strangers in the society. Our intention is to create a DEAF AND DUMB aid that is portable to help them communicate like others. The Dumb uses their hands to communicate with others, these hand signals are to be converted to the common man's language.

A flex sensor glove along with MEMS accelerometer is used to convert the sign language to text format. According to the output values of the flex sensors and MEMS accelerometer, the microcontroller recognizes the corresponding letter or sentence. It is then converted into voice with the help of a voice recorder/playback IC. It is also displayed on the LCD screen.

2. RELATED WORKS

2.1 Real-Time Hand Gesture Recognition for Service Robot

This is a hand gesture recognition for human-robot interaction. This is done by image processing. Images extracted from the video are used to recognize the hand gestures. Hand gestures are recognized using Support Vector Machines (SVMs) [7].

2.2 Real-Time Robotic Hand Control Using Hand Gestures

This is a highly advanced human-computer interaction technology. This system automatically recognizes emotions based on effective state, physiology and behavior of humans. Other recognition methods such as speech, gestures and gaze [3].

3. PROPOSED SYSTEM

3.1 Introduction

There are approximately 70 million people world-wide who are deaf-dumb. They struggle to communicate with normal people since most people don't understand their sign language. This creates a large communication gap between deaf-dumb and normal people. With the use of hand-talk

glove, it is meant to reduce this communication gap. With the implementation of home automation, this could become a life-changer for deaf-dumb people.

3.2 Block Diagram

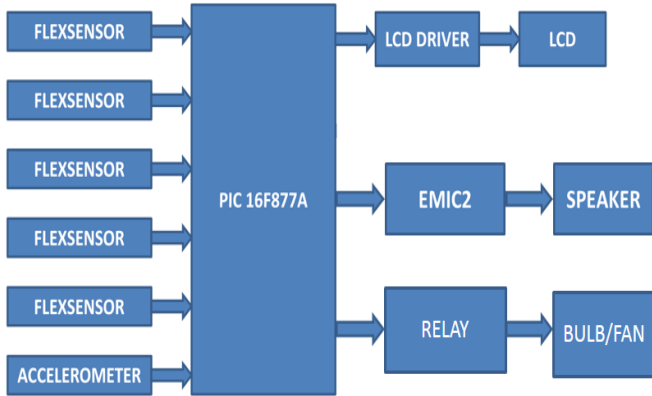

Fig.: 1. Block Diagram

3.3 Block Diagram Explanation

PIC 16F877A is the processing part of the system. Sensors are connected to the ADC of the PIC Microcontroller. Sensors include 5 flex sensors and an accelerometer. There are two possible outputs for each symbol, a text message shown on the LCD screen and a sound heard through the loud speaker. EMIC2 is a text-to-speech module, this module converts text to sound output. Relay connects electronic accessories to the microcontroller, which can be controlled using hand gestures.

4. PROPOSED SYSTEM ARCHITECTURE

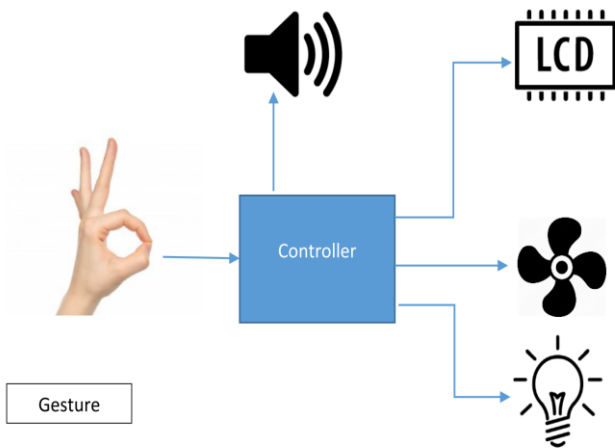

Fig.:2. Proposed system architecture

The figure shows proposed system architecture. An LCD module is connected to the controller for display and a speaker to produce a corresponding sound output, a fan and a bulb are connected using a relay to the microcontroller for home automation. With the help of hand gestures anyone can control the home appliances.

5. ADVANTAGES & DISADVANTAGES

5.1 Advantages

- Eliminates the need for an interpreter.
- Real time translation.
- Portable.
- Trained to translate dynamic signs.
- Low cost and low power consumption.

5.2 Disadvantages

- Limited data.
- Possibility of misinterpretation for closely related gestures.
- Facial expressions are not considered.

6. EXPERIMENTAL SETUP



Fig.: 3. Experimental Setup

The whole system is powered by a 12V DC power supply. PIC18F877A microcontroller acts as the processing unit. An RS232 serial communication port is provided so that the coding process can be carried out anytime it is required. Flex sensors and the accelerometer are mounted on the hand-talk glove, the input is directly fed to the ADC of the PIC. A 16*4 LCD used to display the output. A text-to-speech module called EMIC2 converts the text into spoken words, which is fed to the speaker. To simulate home automation a DC bulb is connected using a relay, the bulb will turn on and off when the corresponding symbols are shown.

7. INDIAN SIGN LANGUAGE SYSTEM

India is a country of great diversity in culture with a population of over 1.2 billion. India also has a number of written and spoken languages. This suggests that India has a number of different sign language systems. Due to this fact a sign language used by one community is not understood by the other, as a result no system of finger-spelling has achieved

any significant level of support among the deaf-dumb community. This pop-ups the importance of developing a device that converts the sign language into a globally recognizable language such as English.

8. HAND-TALK GLOVE FOR COMMUNICATION

The hand-talk glove is mounted with sensors such as flex sensor and accelerometer. Flex sensors are mounted on each finger of the hand-talk glove, accelerometer is placed just above the wrist. When the person shows a symbol, flex sensors and accelerometer produces corresponding values, which are directly fed to the ADC of the microcontroller. For different symbols sensors produce different values. Values of sensors for a particular symbol are stored in the PIC microcontroller. As soon as the symbol has been showed, the microcontroller checks the values of the sensors with the values in the database, if they match corresponding message will be displayed.

9. HAND-TALK GLOVE FOR HOME AUTOMATION

Hand-talk glove can be used for home automation, which is to control electronic home appliances with a dedicated symbol. This eliminates the need for physically turning the device on and off. The person can control all the appliances from where he stands. Two dedicated symbols are required for each appliance, one to turn it on and one to turn it off. In case of a fan, more symbols can be used so that the speed can also be controlled. In addition to home automation, computer interfacing is also possible with hand-talk glove. Using different symbols many functions such as printing, web browsing, music play, etc., can be controlled.

10. HARDWARE AND SOFTWARE DESCRIPTION

The hardware section consists of flex sensors, accelerometer, PIC18F877A Microcontroller, relays, LCD display, EMIC2 text-to-speech module, loud speaker.

Flex Sensor

Flex sensors are type of sensors used to measure the bending. When bending occurs the resistance associated with the flex sensor changes, which can be fed to a PIC for interpretation.

Accelerometer

Accelerometers are used to sense dynamic motions of the glove, which helps to identify dynamic symbols. It is mounted on the glove above the wrist so that the tilt can be measured during dynamic symbols.

PIC16F877A

It is an 8-bit, 40 pin IC, which is the processing part. Output from different sensors are fed to the ADC of the PIC. It has 368bytes of data memory, 8Kbytes of program memory and

256bytes of EEPROM data memory, which are used to store the database.

LCD Display

A 16*4 display is used to display the text output. It is used to display the recognized gesture as a written text output.

EMIC2

EMIC2 is a text-to-speech module, which converts a string of text into speech. Data is transferred serially through RS232 serial communication port. EMIC2 supports two flexlanguages, English and Spanish and 9 different voices.

Software section includes MicroC, Proteus, Bootloader.

MicroC

MicroC is a real-time multitasking operating system kernel for microprocessors, it is used to program the PIC and store the database into its dedicated memory. It uses C programming language.

Proteus

Proteus is a simulation software. It is used to design and test the proposed system.

Bootloader

Bootloader is a burning tool. This is used to transfer the code to the PIC microcontroller.

11. CONCLUSION AND FUTURE WORKS

Due to the fact that there are different sign languages in India, sign languages fail to deliver ideas and eliminate the communication gap between normal people and deaf-dumb. It is so necessary to find a suitable solution to this problem. That's where the hand-talk glove finds its importance. Hand-talk glove converts any sign language to a globally recognizable language such as English, so that any person who can read and write can understand the deaf-dumb. This possibly eliminates or considerably reduces the communication gap between normal people and deaf-dumb. Future works include GPS tracking feature added to the hand-talk glove, face detection for security purpose, addition of external memory so that a large number of signs could be recognized. With little modifications hand-talk glove can be used to play games and simulate virtual reality.

REFERENCES

- [1]. P. Buehler and M. Everingham, "Upper body detection and tracking in extended signing sequences. International Journal of Computer Vision", vol. 95, 180-197, 2011
- [2]. Oya Aran.B.S and in CmpE.M.S, in CmpE, "Vision based sign language recognition: modeling and recognizing solated signs with manual and non-manual components", Graduate Program in Computer Engineering.

- [3]. Jagdish Lal Raheja, Radhey Shyam, Umesh Kumar, Bhanu Prasad, "Real-Time Robotic Hand Control using Hand Gestures", Second International Conference on Machine Learning and Computing, 2010.
- [4]. Mr. Chetan A. Burande, Prof. Raju M. Tugnayat, Prof. Dr. Nitin K. Choudhary, "Advanced Recognition Techniques for Human Computer Interaction", 2nd International Conference on Computer and Automation Engineering (ICCAE), 2010, Singapore.
- [5]. Hatice Gunes, Massimo Piccardi, Tony Jan, "Face and Body Gesture Recognition for a Vision-Based Multimodal Analyzer", conferences in research and practice in information technology, Vol 36, 2004.
- [6]. G.R.S. Murthy, R.S. Jadon, "Hand Gesture Recognition using Neural Networks", Advance Computing Conference (IACC), 2010 IEEE 2nd International, 19-20 Feb. 2010, Patiala.
- [7]. Wang Ke, Wang Li, Li Ruifeng, Zhao Lijun, "Real-time Hand Gesture Recognition for Service Robot", 2010 International Conference on Intelligent Computation Technology and Automation.
- [8]. Chi-Min Oh, Md. Zahidul Islam, Jae-Wan Park and Chil-Woo Lee, "A Gesture Recognition Interface with Upper Body Model-based Pose Tracking", Computer Engineering and Technology (ICCET), 2010 2nd International Conference, 16-18 April 2010, Chengdu.
- [9]. Ms. Shubhangi J. Moon et al./ (IJAEST), "A Real Time Hand Gesture Recognition Technique by using Embedded device", Vol No. 2, Issue No. 1, 043 – 046
- [10]. O. Sugiyama, T. Kanda, M. Imai, H. Ishiguro, and N. Hagita. "Three-layered draw attention model for humanoid robots with gestures and verbal cues", In IEEE/RSJ International Conference on Intelligent Robots and Systems (IROS), pages 2423–2428, 2005.
- [11]. B. Stenger, P. Mendonca, and R. Cipolla. "Model-based 3d tracking of an articulated hand", In IEEE Conference on Computer Vision and Pattern Recognition, pages 310–315, 2001.
- [12]. Steven Douglas Collins, May, "Adverbial morphemes in tactile American sign language graduate college of union institute and university", 1-131, 2004