

DESIGN AND DEVELOPMENT OF REAL TIME RESPIRATORY RATE MONITOR USING NON-INVASIVE BIOSENSOR

Karthik Mohan Rao¹, B.G. Sudarshan²

¹PG Student, Department of Instrumentation Technology, RV College Of Engineering, Bengaluru, India

²Associate Professor, Department of Instrumentation Technology, RV College Of Engineering, Bengaluru, India

Abstract

Respiration Rate is one of the vital signs which require regular monitoring among diseased people. There are a number of medical devices developed to monitor human health condition among them RR monitor is one. The Respiration rate monitor is a device that measures the subject's respiration rate non-invasively. The objective of the proposed work is to design and develop a low cost Respiration rate monitor for clinical applications. The main parameter to be used is the temperature of respired air i.e. both inspired and expired air. Hence this device uses Thermistor as the source sensor which will provide the temperature feedback of the inspired and expired air. The proposed work uses the ATMEL AT89S52 microprocessor with external ADC0809. The magnitude voltage during the inhalation and exhalation is converted into digital signal using ADC. The further process involves a peak detection technique. The number of peaks obtained in duration of one minute gives the Respiration Rate. The so obtained Respiration Rate is sent to the concerned physician's cell phone through GSM modem. The device gives an alarm and sends request via SMS if there is tachypnea and bradypnea.

Keywords: Respiratory Rate, Peak Detection, ADC, GSM, SM, Threshold.

1. INTRODUCTION

Biomedical Engineering is an interdisciplinary field that utilizes concepts and principles of many engineering domains to postulate concepts and techniques useful in designing and building a variety of healthcare products. There are numerous biomedical devices that are in current use, all aimed at improving human health and welfare [1]. Respiration Rate Monitor is one of the biomedical devices that will monitor the subject's breath rate.

The respiratory rate (RR) is the number of breaths taken within a set amount of time (typically 60 seconds) [2]. Normal respiration rates for an adult person at rest range from 12 to 16 breaths per minute. A normal respiratory rate is termed as eupnea, an increased respiratory rate is termed as tachypnea and a lower than the normal respiratory rate is termed as bradypnea [2].

Vital signs are estimations of the body's most fundamental capacities [3]. There are four vital signs that are used for monitoring the patients. They are pulse rate, blood pressure and body temperature, respiratory rate. The respiratory rate is one of the four vital signs (the others being pulse rate, blood pressure and body temperature) that are considered standard for monitoring patients on acute hospital wards. Unusual respiratory rates in the subject judge the serious clinical actions like Cardiac arrest. If the respiratory rate goes high above 27 respirations per minute then it is the mainly important analyst of cardiac arrest [3].

During the respiration there will be a change in respired air temperature, moisture, chemical composition of the air, and in its volume. The breathed out air is hotter than the air that

is breathed in by around 2-3°C much of the time. The breathed in air is at the room temperature which is normally around 25°C (70°F), and the breathed out air has a temperature of around 28°C (82.4°F). If the inspired air is warmer, then the heat lost from the body during the respiration process is lesser [3].

Breathed in air contains dihydrogen monoxide vapor, yet is rarely immersed. The breathed out air is proximately immersed for the temperature at which it leaves the body. In this way, the breathed out air picks up dihydrogen monoxide vapor and carts it away from the lungs [3].

Breathing builds up a transmutation in the chemical composition of the air. Breathed in air embodies around 20.947% of Oxygen (O₂) and 0.033% of Carbon Dioxide (CO₂) by volume, though the breathed out air contains 15.4% of Oxygen (O₂) and 4.3% of Carbon Dioxide (CO₂) by volume. Breathed out air withal contains unstable natural substances in immensely minute amounts [3].

Breathed out air is more massive than breathed in air since it has water vapor added to it, as well as is extended in outcome of its high temperature. In the event that, notwithstanding, it is dried and decreased to the same temperature as the breathed in air, its volume will be found to reduce, since it has lost 5.4 volumes of oxygen for each 43 volumes of carbon dioxide which it has picked up [3].

Many types of respiratory rate monitors have been used for the measurement of the Respiration Rate. Respiration Rate monitor using Ultrasonic Sensor and Respiration Rate monitor using facial tracking method is the non-contact

respiration rate monitoring system. Respiration Rate measurement based on Impedance Pneumography [8] and Respiration Rate measurement based on the Thoracic Expansion include the sensor that are placed on the thorax [7]. Respiration Rate monitor with MEMS based Capacitive Pressure Sensor[9], Respiration Rate monitor with temperature sensor, Respiration Rate meter—a low-cost design approach uses sensors that are mounted within the oxygen mask[7].

Development of a respiration rate meter, a low-cost design approach uses a displacement transducer with infrared (IR) - transmitter and IR-receiver for sensing the Respiration Rate [7]. Respiration Rate Monitor based on Impedance Pneumography measures changes in the electrical impedance of the person's thorax caused by respiratory or breathing [8]. Respiratory Monitoring System Based on the Thoracic Expansion Measurement uses respiratory sensor belt that made up of plastic tube container, Axis, spring, Bumper edge, reflective objective sensor [6]. Temperature sensor based Breath Rate Monitor [7] is a real-time system that computes the respiratory rate of the patient. The system will activate an alarm on crossing the lower or upper respiratory rate limit and simultaneously it will send a SMS to the concerned doctor's cell phone. This system uses a temperature sensor to keep track of the temperature of the respired air [7]. Facial Tracking Method for Non-contact Respiration Rate Monitor involves tracking a facial region of interest (ROI) associated with respiration in thermal images [8]. A new Scheme of Respiration Rate Monitor uses a MEMS based capacitive nasal sensor system for measuring Respiration Rate (RR) [9]. The ultrasonic breathing monitor uses ultrasonic source and transducer for the measurement of frequency shift between the exhaled air flow and the ambient environment [10].

2. SENSOR AND DIFFERENTIAL AMPLIFICATION

2.1 Sensor

The proposed work uses Thermistor as the source. A Thermistor is a thermally sensitive resistor. Its resistance varies according to the variation in temperature. There are two types of Thermistor. They are positive temperature coefficient Thermistor and negative temperature coefficient Thermistor. In positive temperature coefficient Thermistor, resistance increases when there is an increase in temperature. And in negative temperature coefficient Thermistor, resistance decreases when there is an increase in temperature [11].

The proposed model uses a negative temperature coefficient 10k Thermistor (NTC 10k). This Thermistor has wider resistance range up to 10k and it is cost-effective. The temperature ranges from 55°C to +125°C [12]. In the proposed model Thermistor is utilized as a part of a potential divider unit to measure its electronic activity [11]. The Thermistor is mounted within the mask near to the

nostrils to give the temperature feedback of inhaled and exhaled air [3].

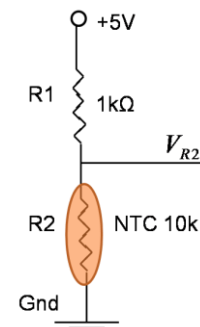

Fig -1: Potential divider circuit using Thermistor [11]

Fig -1 shows the voltage divider circuit. The resistor 1kΩ is added in series with the Thermistor NTC 10k and the voltage of 5V is supplied across the resistors R1 and Thermistor R2. The voltage across the Thermistor is taken as V_{R2} and is measured using Voltage divider formula given below.

$$V_{R2} = \frac{5.R2}{R1 + R2}$$

During inhalation and exhalation there will be a minimum change in Thermistor voltage. This small change of voltage is not enough to be understandable by the ADC. So the Thermistor voltage should be amplified using an amplifier. The current work uses a differential amplifier to obtain an appropriate amplified voltage signal.

2.2 Differential Amplification

A differential amplifier is a type of electronic amplifier that amplifies the difference between the two input voltages but suppresses any voltage common to the two inputs. It is an analog circuit with two inputs and one output in which the output is ideally proportional to the difference between the two voltages with some gain.

The change in the Thermistor output voltage upon breathing isn't satisfactory and doesn't yield appreciable results. Hence, this voltage is fed into the differential amplifier with another constant voltage of 5V as a reference voltage.

The proposed work uses differential amplifier INA122. This amplifier has excellent performance with low quiescent current of 60mA. It has a wide power supply range from 2.2V to 36V [13]. The amplifier has a low offset voltage of 250mV max, low input bias current of 25nA max, low offset drift of 3mV/°C max and low noise of 60nV/√Hz [13].

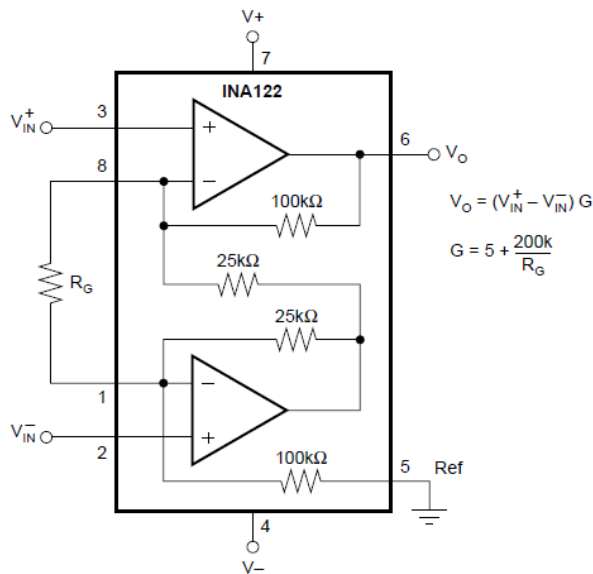

Fig -2: Internal circuitry of differential amplifier INA122 [13]

The fig -2 shows the internal circuitry of differential amplifier INA122. The amplification gain can be adjusted by connecting suitable resistor to the pin 1 and pin 8. And gain and amplified output voltage can be calculated using formula given below [13].

Gain,

$$G = 5 + \frac{200k}{R_G}$$

Differential Amplifier Output,

$$V_O = (V_{IN}^+ - V_{IN}^-)G$$

3. MICROCONTROLLER AND HARDWARE INTERFACING

The Thermistor NTC 10k is placed within the mask and is utilized as a part of a potential divider unit to measure voltage across it. The Thermistor voltage V_{R2} is fed into the differential amplifier as one input V_{in}^+ . And another constant reference voltage of +5V is fed into the differential amplifier as other input V_{in}^- . The voltage difference is amplified with some gain G and resultant voltage signal is to be converted into digital signals. Hence analog to digital converter (ADC) is used to convert the analog signal into a digital signal. And then the digital signal is sent into the microcontroller to proceed with data logging. LCD is used to display the results. GSM modem is used to send the SOS request through SMS to the concerned physician's cell-phone.

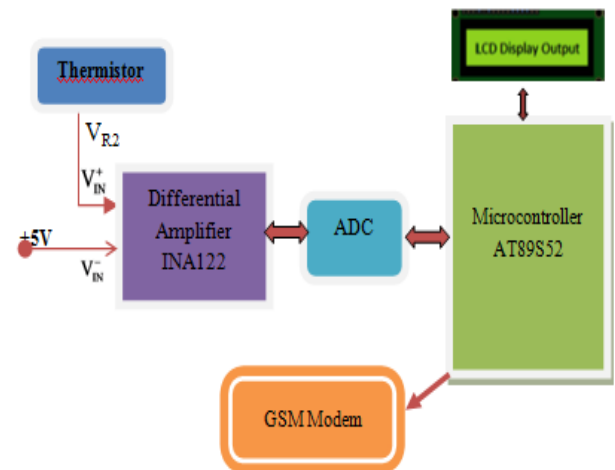

Fig -3: Block Diagram of the Hardware System

3.1 Analog to Digital Converter

An analog-to-digital converter is a device that converts an analog voltage to a digital number that represents the analog voltage amplitude. This proposed work uses ADC0809 analog to digital converter because it is the easy interface with all microprocessors [14]. This ADC operates with 5 V_{DC} . It has 8-channel multiplexer with address logic, 8 bit resolution, 0V to 5V input range with single 5V power supply, standard hermetic or molded 28-pin DIP package. This ADC consumes low power of 15 MW and it takes 100 μs for the data conversion. The data conversion takes place using equations given below [14].

$$Q_{Step} = \frac{V_{Rcf(+)} - V_{Rcf(-)}}{2^8}$$

$$Digital - data = \left(\frac{V_{in}}{Q_{Step}} - 1 \right)_{10}$$

For example [14], conversion of 4.5V to digital value $V_{Rcf(+)}=5.04V$ (as per the design)

$V_{Rcf(-)}=0V$ (as per the design)

Finding the Q step, $Q_{step} = (5.04-0)/2^8 = 0.0196875$

Digital Data = $[(4.5/0.0196875)-1] = 227.57 = (227)_{10}$

Therefore, digital value of 4.5V is 227.

3.2 Microcontroller

The current work utilizes 8051 AT89S52 microcontroller. The microcontroller has 8K bytes of In-System Programmable (ISP) flash memory and it operates for the voltage of 4.0V to 5.5V [15], the operation is static for 0 Hz to 33 MHz frequency. This work uses 11.0592MHz crystal for the operation [15]. The microcontroller has 256 x 8-bit Internal RAM, 32 programmable I/O lines, three 16-bit Timer/Counters, Full Duplex UART Serial Channel, fast Programming Time [15]. This microcontroller makes use of external ADC for the operation.

4. FLOWCHART

As the Thermistor resistance changes during inspiration and expiration, voltage across the Thermistor also changes. There will be a little change in the Thermistor voltage during inhalation and exhalation which is not detected by the ADC. Hence the Thermistor voltage is amplified using INA122 differential amplifier with a constant reference voltage of +5V. The ADC gives the values corresponding to input voltage given from the differential amplifier. The digital values of ADC go high and low for a respiration. Hence there exist many peaks in a minute of respiration. Counting these peaks for duration of one minute gives the respiration rate.

4.1 Algorithm for the Peak Detection

- Step 1:** ADC_prev to 0; Initializing(assuming) previous ADC value to zero
- Step 2:** Compare current_ADC & ADC_prev; compare obtained ADC value with previous value
- Step 3:** Is current current_ADC value > ADC_prev?
YES: ADC_prev= current_ADC value ; assume obtained ADC value as previous value.
 Go to Step 2
NO: "PEAK DETECTED"

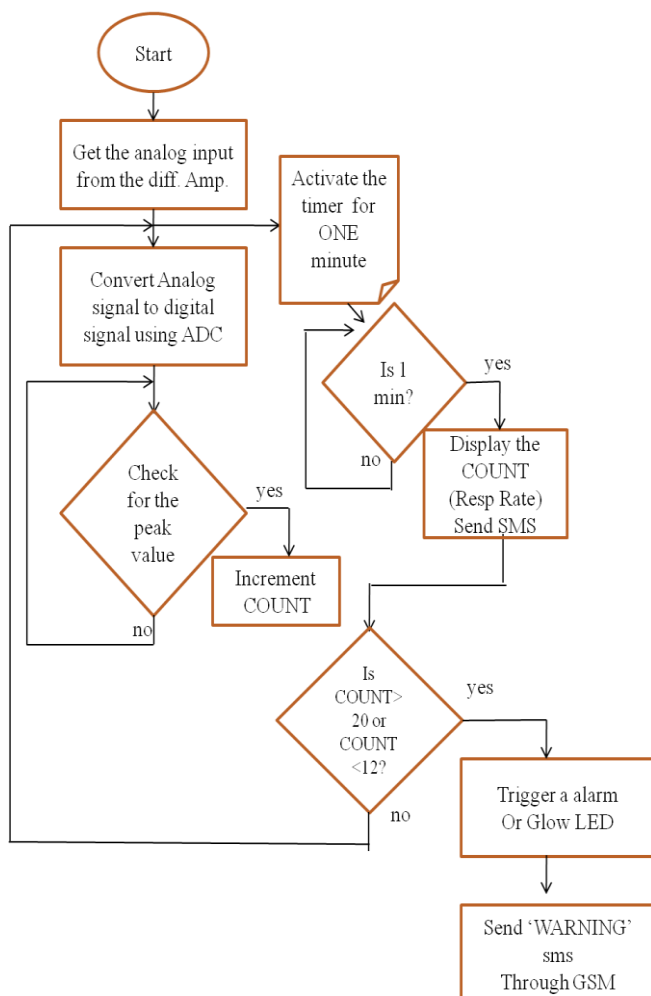

Fig -4: Flowchart of the System

5. RESULTS

The objective of the proposed work is to develop a non-invasive Respiratory Rate monitor that provides Real time output. The work uses Thermistor, voltage divider circuit, differential amplifier, ADC. The output result at each unit can be measured. Hence the result part is classified into five stages. First stage is to observe the Thermistor resistance change during the respiration. Measuring the voltage change across Thermistor during respiration is the second stage. Third stage is to measure the output voltage from the differential amplifier. Fourth stage is to observe the digital value converted by Analog to Digital Converter. Final output stage will give the respiration rate of the subject and then it is displayed on the LCD.

5.1 Stage I

As per the experimental observation, the resistance of the Thermistor was around 9.04kΩ at room temperature.



Fig -5: Thermistor resistance at room temperature

During the respiration process, there will be a sudden change in the resistance. I.e., during exhalation phase the resistance goes low from 9kΩ to 7.32kΩ and during the inhalation phase the resistance goes high from 7.32kΩ to 8.2kΩ as shown below.

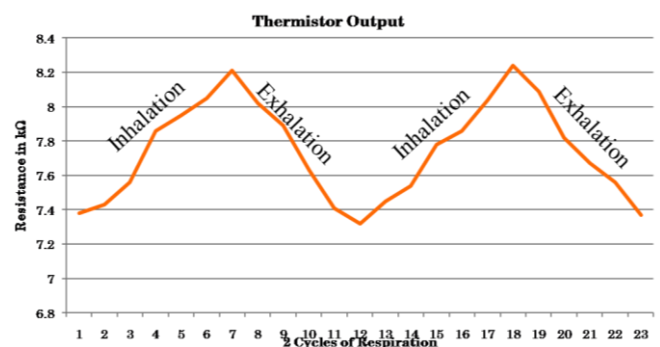

Fig -6: Change in Thermistor resistance for 2 cycles of respiration

Table -1: Change in Thermistor resistance during two phases of respiration for 2 cycles

Cycle 1		Cycle 2	
Inhalation	Exhalation	Inhalation	Exhalation
7.38	8.02	7.45	8.09
7.43	7.93	7.54	7.82
7.56	7.89	7.78	7.67
7.86	7.63	7.86	7.56
7.95	7.41	8.04	7.44

8.05	7.32	8.24	7.37
8.21			

5.2 Stage II

Stage 2 gives the Thermistor voltage during the Respiration. The voltage across Thermistor can be measured in the voltage divider circuit. The voltage change across the Thermistor is very less i.e., from 4.19V to 4.21V for inhalation and from 4.2V to 4.19V for exhalation phase as shown below

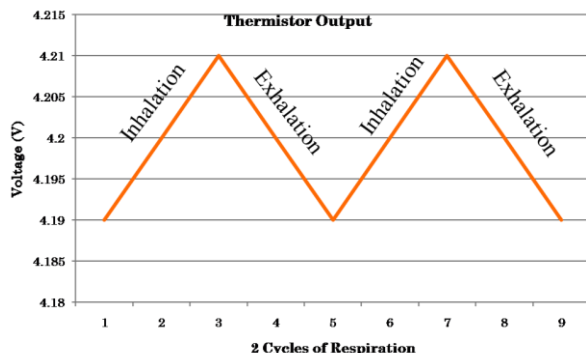

Fig -7: Change in Thermistor voltage for 2 cycles of respiration

Table -2: Change in Thermistor voltage during two phases of respiration for 2 cycles

Cycle 1		Cycle 2	
Inhalation	Exhalation	Inhalation	Exhalation
4.19	4.2	4.2	4.2
4.2	4.19	4.21	4.19
4.21			

5.3 Stage III

Stage 3 gives the differential amplifier output voltage during the Respiration process. The differential amplifier output voltage change is from 3.92V to 4.12 for exhalation and 4.1V to 3.9V for inhalation as shown below.

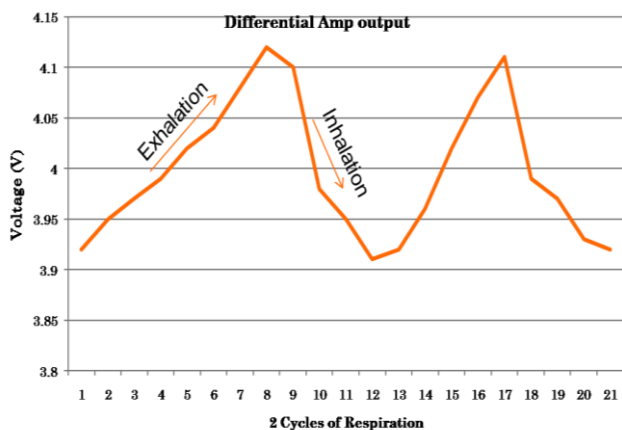

Fig -8: Change in differential amplifier output voltage for 2 cycles of respiration

Table -3: Change in differential amplifier output voltage during two phases of respiration for 2 cycles

Cycle 1		Cycle 2	
Exhalation	Inhalation	Exhalation	Inhalation
3.92	4.1	3.92	3.99
3.95		3.96	
3.97	3.98	4.02	3.97
3.99		4.04	
4.02	3.95	4.07	3.93
4.04		4.08	
4.08	3.91	4.11	3.92
4.12			

5.4 Stage IV

Stage 4 gives the ADC output value which was displayed on the LCD during the Respiration process. As per the experimental observation, the value goes high from 195 to 208 for exhalation and from 204 to 194 for inhalation phase as shown in the Fig. and Table. This is an advantage to find the peak value during respiration process.

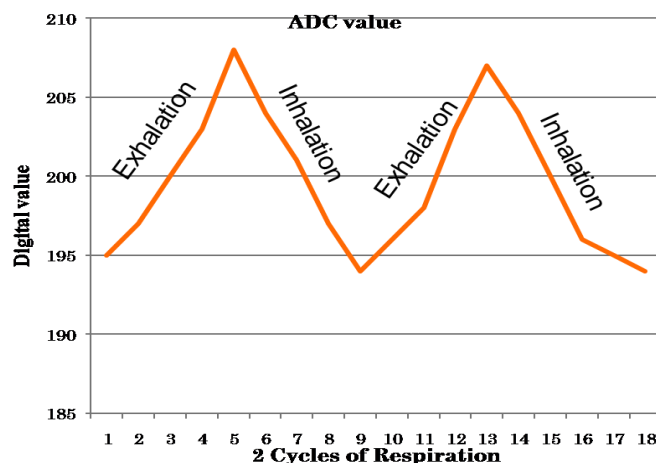

Fig -9: Change in ADC output value for 2 cycles of respiration

Table -4: Change in ADC output value during two phases of respiration for 2 cycles

Cycle 1		Cycle 2	
Exhalation	Inhalation	Exhalation	Inhalation
195	204	196	204
197	201	198	200
200	197	203	196
203	194	207	195
208			194

5.5 Final Result

After counting the peaks in the digital values for a minute, the system displays the Respiration Rate, and it sends the Respiration Rate through GSM unit.



Fig -10: Respiration Rate on the LCD

If the Respiration Rate crosses its upper and lower threshold limit, the system gives the warning alert as shown in the Fig -11 and it sends the SMS as "Warning" through GSM unit.



Fig -11: Warning alert on the LCD

6. CONCLUSION

Respiratory rate is one of the central signs that are seen as standard for watching patients on unbearable facility wards. To quantify Respiration Rate a portable apparatus is developed. The Thermistor utilized by the apparatus as the sensor gives the best response during respiration process. In this work, output result at each stage is studied and the device is able to give the desired result. Since the apparatus uses the Thermistor as the sensor, the device is cost effective and it gives the real-time output. And also the system is capable of identifying eupnoea, tachypnea and bradypnea.

REFERENCES

- [1]. "Bioengineering and Biomedical engineering in Europe", Achieved by University of Craiova (Romania) Biomechanics Institute of Valencia (Spain) Democritus University of Thrace (Greece), 2012.
- [2]. Respiratory rate, "https://en.wikipedia.org/wiki/Respiratory_rate", Wikipedia Encyclopedia, June 2015.
- [3]. Sumanta Bose, Prabu K, Dr. D. Sriram Kumar, "Real-Time Breath Rate Monitor based Health Security System using Non-invasive Biosensor", Third International Conference on Computing Communication & Networking Technologies (ICCCNT), IEEE 2012.
- [4]. Souvik Das, "Development of a Respiration Rate meter –a low-cost design approach", Health Informatics - An International Journal (HIJ) Vol.2, No.2, May 2013.
- [5]. Amit K. Gupta, "Respiration Rate Measurement Based on Impedance Pneumography", Texas Instruments Application report SBAA181–February 2011.
- [6]. Fabiola Araujo Cespedes, "Respiratory Monitoring System Based on the Thoracic Expansion Measurement", University of South Florida Scholar Commons, Graduate Theses and Dissertations, January 2012.
- [7]. Sumanta Bose, Prabu K, Dr. D. Sriram Kumar, "Real-Time Breath Rate Monitor based Health Security System using Non-invasive Biosensor", Third International Conference on Computing Communication & Networking Technologies (ICCCNT), IEEE 2012.

[8]. F. Q. AL-Khalidi, and R. Saatchi, D. Burke and H. Elphick, "Facial Tracking Method for Noncontact Respiration Rate Monitoring", 7th International Symposium on Communication Systems Networks and Digital Signal Processing (CSNDSP), IEEE 2010.

[9]. Madhurima Chattopadhyay, Deborshi Chakraborty, "A New Scheme for Determination of Respiration Rate in Human Being using MEMS Based Capacitive Pressure Sensor: Simulation Study", Proceedings of the 8th International conference on Sensing Technology, Sep 2014, Liverpool, UK.

[10]. Philippe Arlotto, Michel Grimaldi, Roomila Naeck and Jean-Marc Ginoux, "An Ultrasonic Contactless Sensor for Breathing Monitoring", Sensors 2014, 14(8), 15371-15386; doi:10.3390/s140815371.

[11]. Balraj A, Prof. Amit Patvardhan, Renuka Devi V, Aiswarya R and Prasen V, "Embedded Temperature Monitoring and Control Unit", International Conference on Recent Trends in Information, Telecommunication and Computing IEEE 2010.

[12]. EPCOS India Private Ltd., "NTC Thermistor for temperature measurement", Datasheet of NTC 10k, March 2006.

[13]. Burr-Brown Corporation, "Single Supply, Micro Power Instrumentation amplifier", Datasheet of INA122, 1997.

[14]. National Semiconductor, "ADC0808/ADC0809, 8-Bit μ P Compatible A/D Converters with 8 Channel Multiplexer", Datasheet of ADC0809, 1999.

[15]. Atmel Corporation, "8-bit Microcontroller with 8K Bytes In-System Programmable Flash-AT89S52", Datasheet of 8051 Atmel AT89S52.

BIOGRAPHIES

Karthik Mohan Rao received the B.E. degree in Electronics and Communication engineering from Vivekananda college of Engineering Technology, Puttur, India and pursuing M.Tech. degree in Biomedical Signal Processing and Instrumentation engineering in RV College Of Engineering, Bengaluru, India.

Dr. B.G. Sudarshan working as Associate Professor, Department of Biomedical Signal Processing & Instrumentation, RV College Of Engineering, Bengaluru, India