

HOME APPLIANCE CONTROLLING USING ZIGBEE ON ATMEGA128 HARDWARE PLATFORM.

Manish Kumar¹, Ramandeep singh²

¹Student, EECE Department, ITM University, Gurgaon, Haryana, India

²Assistant Professor, EECE Department, ITM University, Gurgaon, Haryana, India

Abstract

The demand of wireless system in home is increasing day by day due to its cost and easy placement and also it is easy to connect with our computer or phone [1]. This project demonstrates about the control of home appliances wirelessly using computer and Zigbee wireless communication protocol. We can control the home appliance like refrigerator, fan, and air conditioner etc. by sending command through the computer. Input will be given from the computer through serial communication. By this technique we can also control all electrical appliances within a room in a building. We extend the concept of controlling the power supply for the devices at remote location at home or industry.

KeyWords: Home Automation, Zigbee, AVR, ATMEGA128, Smart homes, wireless automation, XBee S2, embedded system.

1.INTRODUCTION

Home automation is combination of computer/microcontroller and information technology to control the home appliance. System can control through computer or other embedded system by using intelligence of system and automation. it is made for several reasons of energy efficiency, security and ease [2].

In this era construction of industries and homes contains the wiring for telephones, TV outlets, electrical power, broadband wire, a doorbell and door lock [1-2]. Special appliance is developed to automation in home automation. Many appliance are made to reduce the manual labor for example washing machine is were developed for reducing the manual labor for clothes cleaning and for bathing the water heaters also reduced the necessary labor.

The number of electrical devices are increasing day by day so interconnection of device and communication within device is very useful between appliance and communication between them is very likable feature. For example, an air conditioner will send a message on owner's phone when it require for cleaning, or an air cooler when it require its service. The embedded system is work as virtual intelligent system in which doors will become "Intelligent" and it will send signals to the microcontroller when someone enters [3]. If alarm system is set and no one is in the home, the system could call/SMS to the owner, or the saved neighbor's number, or an emergency number.

There are various number of wireless device used in home automation like Bluetooth, Zigbee, GPRS etc. [4]. Bluetooth needs passkey on every new connections and GPRS required internet at both transmitter and receiver end so I

use Zigbee for home automation. Zigbee is used for short distance communication.

Zigbee wireless technology is developed as an open global standard of low power, low cost, wireless M2M networks it is based on IEEE 802.15.4 standard and operates in unlicensed band 868MHz, 915 MHz, and 2.4 GHz [5]. The Zigbee device can communicate at maximum speed of 250kbps at 2.4 GHz frequency. Data rate is 20kbps at 868MHz and 40kbps at 915MHz [6]. The Zigbee device can communicate of up to 50 meters in typical environment circumstance and distance is maximum when environment is ideal. Zigbee gives high data throughput in all application where the duty cycle is low [7]. Due to this features Zigbee is ideal for home, industrial automation, business, where sensor and control devices are used.

1.1 Types of Zigbee

There are three types of Zigbee devices:-

Zigbee Coordinator (ZC): the Zigbee coordinator device form the root of network tree and might bridge to the other network. In each network there are one Zigbee coordinator which initiate the network originally .It store information of the network and working as a trust center.

Zigbee Router (ZR): it will work as an intermediate router, its take data from one router and passing it to other router.

Zigbee End Device (ZED): it contains less functionality as compare to ZC and ZR. It have functionality to communicate with parent node. It cannot route data but the node is allows to sleep for a significant amount of time while it is not transmitting. So it's give long battery life. It required less amount of memory than ZR and ZC.

2. BLOCK DIAGRAM

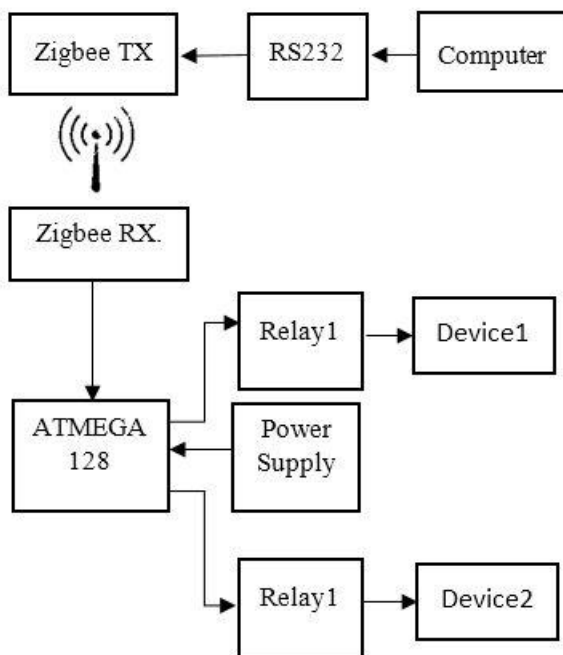

Fig -1: Block diagram of Zigbee based home appliance controller

The given embedded system is used for controlling home appliance using your pc and Zigbee. All appliance are connected with microcontroller or through relay. The command is send through hyper terminal or X-CTU software.

In this embedded system there are two part, one is transmitter and one is receiver. The transmitter contains Zigbee transmitter and RS232 circuit and receiver contains Zigbee receiver and ATMEGA128 which is connected with relay and appliance i.e. fan, bulb, motor etc. [8].

The command is send through pc hyper terminal. The command is transmitted through Zigbee transmitter. The Zigbee receiver receive the command and after decoding it will send command to ATMEGA128. The micro-controller respond according to the command. for example if we send command 1 to microcontroller the fan will on and when command 2 to the microcontroller the motor will on. If we send wrong command to microcontroller then it will glow a red LED on the board.

The hardware consideration of this embedded system is, it use pc for transmit a command. The command is send over Zigbee wireless and the Zigbee receiver receives the command and after decoding send command to ATMEGA128. All AC devices are connected through relays when the microcontroller transmit 1 to relay the corresponding device is on and when transmit 0 to relay the device is off.

3. FLOW CHART

When power is on the system is initialize and establish network between both Zigbee modules. Zigbee takes few seconds to initialize. After initialization Zigbee receiver and transmitter are establish network wirelessly. The command will send through Zigbee transmitter and collect information in receiver module. If serial data received the command is send to microcontroller if not then waiting for serial data.

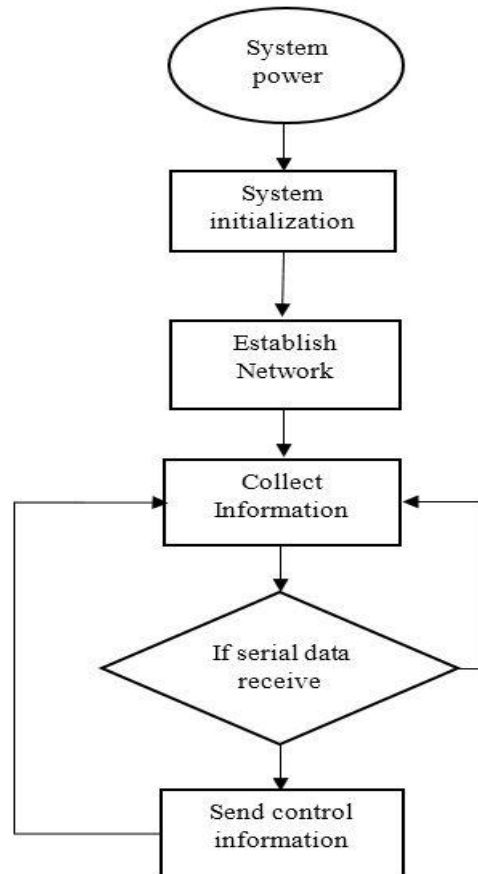

Fig -2: Flow chart

4. HYPERTERMINAL SCREENSHOT AND DESCRIPTION

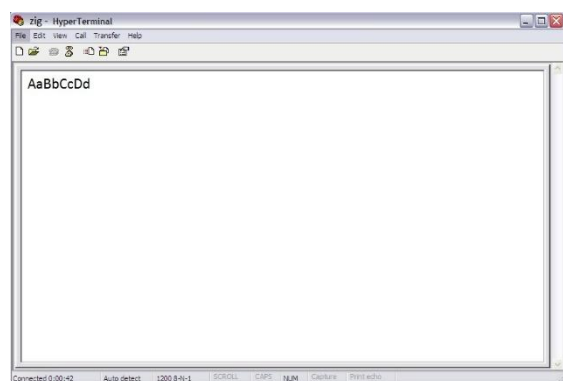

Fig -3: HyperTerminal

HyperTerminal is a software which runs on windows platform and it offers to control remote device by sending text based command. It is used for local serial interface for communication or network. In my embedded system, by sending 'A' the fan is on and by sending 'a' the fan is off. Bulb is on and off through command 'B' and 'b' similarly AC is turn on and off by sending command 'C' and 'c'. To turn on and off the gate lock we have to send command 'D' to on and command 'd' to off.

5. COMMANDS AND PACKET FORMAT GENERATED

Table -1: Commands on HyperTerminal

Command	Connected on PIN	Serial communication data command for ON/OFF
Fan On/Off	PORTA.0	A/a
Bulb On/Off	PORTA.1	B/b
AC On/Off	PORTA.2	C/c
Gate Lock On/Off	PORTA.3	D/d

6. APPLICATIONS

The application of Zigbee is where, we require, low data rate, low power consumption, low cost, security and reliability [9-10]. Zigbee is used in several field like medical, industry automation, home automation etc.

Table -2: Applications

CATEGORY	APPLICATION
Vital Monitoring	Heart-rate Monitoring
	Body heat Monitoring
	Personal equipment control
Consumer Electronic	Remote control
	PC- peripheral
	Control of windows roll/shades etc.
	Dimmer/ switches
Alarm And security system	Smoke detector
	Water leakage alarm

7. ADVANTAGE AND LIMITATION

The advantage of Zigbee home automation is, it low power consumption device and very less time consuming system. Zigbee home automation make home safe and comfortable. Home automation takes less time to finish a task and also makes the work simpler. The wireless range of Zigbee is good enough for home automation. The range of Zigbee is 100 to 300 feet approx. The overall system cost is very low as compare to other. The cost is dependent on advancement of system.

The limitation of the Zigbee home automation is If there any damage due to rupturing of cable the entire system get crashed and If he/she doesn't use the correct keys to perform the operations, human errors may occurs [11-12]. In very rare case, the reliability of home automated device is decreases [13].

8. RESULT

The proposed system is made for transmit the command wireless through Zigbee. The Zigbee module transmit command from PC hyper terminal to other Zigbee module which is connected to AVR microcontroller. The second Zigbee module receive the command from first Zigbee module and send to microcontroller. Microcontroller take action according to the command.

9. CONCLUSION AND FUTURE SCOPE

This paper present a wireless home automation which is controlled by PC. In proposed architecture XBEE module is used for wireless transmission and command is send from hyper terminal of PC.

In future, the transmitter side Zigbee is replace by remote Zigbee. Which contain a microcontroller push button switch for command.

10. ACKNOWLEDGEMENT

I am always grateful to my professors, lab assistant all staff of electrical and electronics communication engineering department for their support and also thanks to my college management team for providing me the most advance lab for project work.

11. REFERENCES

[1] Woo Suk Lee, Seung Ho Hong "KNX Zigbee Gateway for Home Automation" ,4th IEEE Conference on ASE, August 23-26, 2008
 [2]. A Zigbee-based home automation system. IEEE Transactions on Consumer Electronics, 55 (2), pp. 422-430. ISSN: 0098-3063
 [3]. Zigbee based home appliance controlling through spoken command using handheld device, IJSM, Vol. 7 , NO. 1, January 2013.
 [4]. wireless home automation system using Zigbee, IJSER, vol. 3, issue 8, August-2012, ISSN 2229-5518.

- [5] Khusvinder Gill, Shuang-Hua Yang, Fang Yao, and Xin Lu "A ZigBee-Based Home Automation System" IEEE Transactions on Consumer Electronics, Vol. 55, No. 2, MAY 2009.
- [6].Kwang-il Hwang, Byoung-Jo Choi, Seok-hoon Kang, "Enhanced Self-Configuration Scheme for a Robust ZigBee-based Home Automation" IEEE 2010.
- [7].Dae-Man Han and Jae-Hyun Lim "Smart Home Energy Management System using IEEE 802.15.4 and ZigBee" IEEE 2010.
- [8]. Wang Weihong, Xia Liegang " Design and Implementation of a Control System Using AVR Microcontroller "College of Software, Zhejiang University of Technology" IEEE 2009
- [9]. Liu Wei, Gao Yonghui, Jiang Wenlong, Ren Tao "Remote Control of Smart Household Based on DTM" IEEE 2010.
- [10]. Hannu Järvinen, Andrey Litvinov, Petri Vuorimaa, "Integration Platform for Home and Building Automation Systems" 5th IEEE Workshop on Personalized Networks 2011.
- [11]. Chunlong Zhang, Min Zhang, Yongsheng Su, Weilian Wang, "Smart Home Design based on ZigBee Wireless Sensor Network"2012 7th International ICST Conference on Communications and Networking.
- [12]. Alexandru-Corneliu Olteanu, George-Daniel Oprina, Nicolae pu and Sven Zeisberg " Smart Home Design based on ZigBee Wireless Sensor Network"2013 19th International Conference on Control Systems and Computer Science.
- [13]. Falk-Moritz Schaefer, Tobias Groß and Rüdiger Kays "Energy Consumption of 6LoWPAN and Zigbee in Home Automation Networks" IEEE 2013.

11. BIOGRAPHIES



Manish kumar is currently pursuing masters of technology in embedded system from ITM University, Gurgaon. He completed his B. Tech in Electronics and communication from Institute of Technology and Management, Bhilwara, Rajasthan in 2013. His area of interest is

low power embedded system and wireless communication between embedded systems.



Ramandeep Singh is an Assistant Professor in EECE Department of ITM University, Gurgaon. He is pursuing Ph.D. in embedded systems from ITM University. In 2009 he has completed M.E. in embedded systems. He is a B. Tech. graduate from GGSIPU, Delhi. His

core research areas are low power embedded systems, robotics, FPGA based embedded systems and SCADA. Prior to joining ITM University he has worked with NXP Semiconductors Bangalore. He has various publications in international journals and conferences.