

INTELLIGENT POLLUTION MONITORING USING WIRELESS SENSOR NETWORKS

Gokulram.K¹, Dhakshinamoorthy.T²

¹ P.G Scholar, Electrical and Electronics Engineering, Kumaraguru College of Technology, Tamilnadhu, India

² Asst.Professor, Electrical and Electronics Engineering, Kumaraguru College of Technology, Tamilnadhu, India

Abstract

This paper provides an idea to deal with several pollution control measures existing in industries. The pollution likes air pollution due to release of toxic gases in the industry affects the entire human environment. Similarly, the motion of any living beings in any restricted area is identified through a PIR sensor. And, finally the water pollution by letting the improperly treated waste water into the river affects the entire eco system. Air pollution can affect many body organs and systems in addition to the environment. By the report of the World Health Organization (WHO), air pollution is significant risk factor for multiple health conditions including skin and eye infections, irritation of the nose. The purity of water content released from the industry is checked through a pH meter the eel of purity of water should be beyond the standard specified by the pollution control board. This paper helps in neglecting those factors affecting the human environment through pollution.

Key Words: GSM, Wireless Sensor Networks (WSN), pH Meter, Gas Sensor, Pollution control board

-----***-----

1. INTRODUCTION

Several health problems likes heart disease, lung cancer, pneumonia, bronchitis, difficulty in breathing and coughing due to aggravated asthma [1] arises due to air pollution. Air pollution can affect many body organs and systems in addition to the environment. By the report of the World Health Organization (WHO), air pollution is significant risk factor for multiple health conditions including skin and eye infections, irritation of the nose, throat and eyes [2].

So, it becomes very essential to monitor and control the air pollution and the best way to control air pollution is to monitor exceeding levels of air pollutants and by taking appropriate actions to control it [3]. Several techniques can be used to monitor air pollution data. The atmospheric pollution is emitted from factory chimneys in our state, however, due to the factory chimneys have characteristics such as widespread distribution range and high altitude, the environment protection departments have some difficulties in monitoring the industry chimney, which causes that the large factory chimneys drain the polluted waste gas into the sky secretly and arbitrarily, and results in deterioration of the environment.

Air pollution leads to instability, harmful and undesirable effects in the environment [4]. With the rapid growth of industrialization, environmental pollution has become a large area of concern. The primary pollutants are Carbon monoxide is a very poisonous gas. It is produced by incomplete combustion of fuel such as coal or wood, natural gas [5]. Vehicular exhaust is one of the primary sources of carbon monoxide. Road vehicles produce 91% of all CO emissions. When inhaled it

can reduce the oxygen carrying capacity of one's blood and can cause headache or fatigue.

They also combine with hydrocarbons to form low level ozone and may cause lung disease. Sulphur di oxide which is produced in various industrial processes. The oxidation of SO₂ in the presence of catalysts like NO₂ forms H₂SO₄, which is acid rain and causes damage to environment [6]. For the control of the air pollution in the environment it needs continuous monitoring of the quantity of gases present in the environment. This helps government officials, tourist and insurance companies, international organizations, and individuals to access the pollution data [7].

The motion of human beings around any restricted through the PIR sensor thus preventing them from any danger that occurs to them. Water pollution is considered as the major problem.

All these problems are identified through an embedded controller by acquiring the signals from the sensors. The three basic sensors used for this purpose are PIR sensor to identify the identify human beings in the restricted area. Similarly, the purity of water content released from the industry is checked through a pH meter the eel of purity of water should be beyond the standard specified by the pollution control board. And finally, the merge of toxic gases is identified through the gas sensor when the level exceeds the standard maintained by the pollution control board then necessary action should be taken.

When these above problems are identified a message is sent to the owner of the industry through mobile and the owner should take the proper pollution measures within a

specified period of time. After a specific point of time, if no proper pollution control measures are taken then a message will be sent to the pollution control board through mobile.

By this scheme the environment can be saved from different kinds of pollution problems thus enhancing the life of human as well as the complete eco system. These measures are taken according to the standards mentioned by the pollution control board which enriches the surrounding.

2. BACKGROUND

Different types of sensors are used to implement this idea. The signals acquired from the sensors are processed in the controller and proper control measures are taken.

GSM, which is used to transmit the message from a controller to the mobile possess three basic structures like base station subsystem, networking and switching subsystem and the GPS core network.

A pH meter which is used to check the alkalinity of consists of a special measuring probe which is a glass electrode connected to an electronic meter that measures and displays the pH reading.

A gas detector that detects the existence of various gases whose standard is above the level specified by the controller. This type of equipment is used to detect a gas leak and interface with a control system so a process can be automatically shut down. A gas detector identifies any leak occurrence and produces an alarm thus giving the human beings an opportunity to leave the area. This type of device is important because there are many gases that can be harmful to organic life, such as humans or animals.

Gas detectors are usually battery operated. They transmit warnings via a series of audible and visible signals such as alarms and flashing lights, when dangerous levels of gas vapours are detected. As detectors measure a gas concentration, the sensor responds to a calibration gas, which serves as the reference point or scale. As a sensor's detection exceeds a pre-set alarm level, the alarm or signal will be activated. As units, gas detectors are produced as portable or stationary devices. Originally, detectors were produced to detect a single gas, but modern units may detect several toxic or combustible gases, or even a combination of both types.

In this system model, the gas sensor is used to monitor Carbon di-oxide presence and volume in the industrial outlet. Similarly the liquid effluents are monitored using the pH meter. The memory of the system is used as per DAQ and processing requirements of the system.

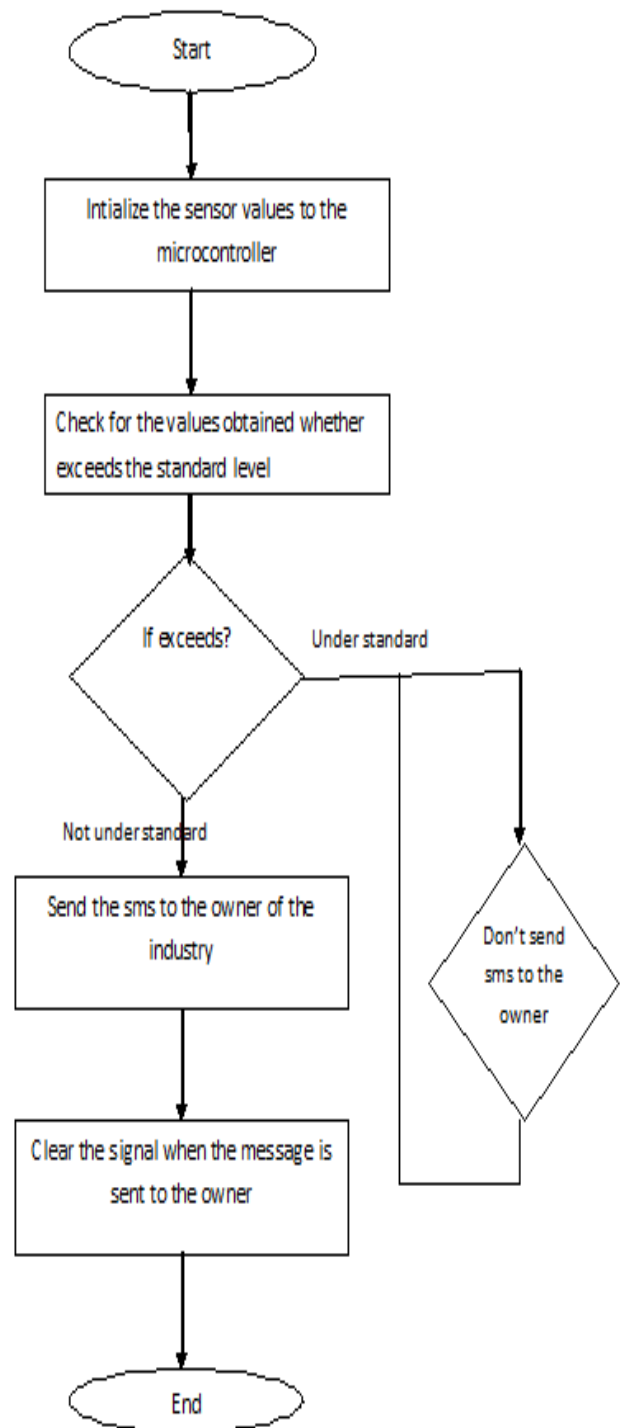

Fig-1. Flow chart to representing the idea

3. OPERATION

As shown in figure 2 the block diagram of the system the signals of gas found and water lever will be measure by the sensor and acquired by the controller. When the signal level measured exceeds the reference value as specified in the controller a message will be sent to the owner of the industry and after a specific interval of time if no proper measure is taken a message will be sent to the pollution control board through GSM.

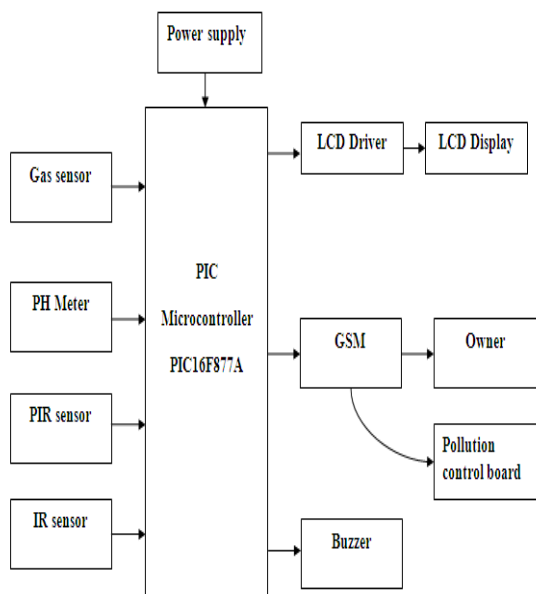

Fig -2. Block diagram of system

4. SIMULATION

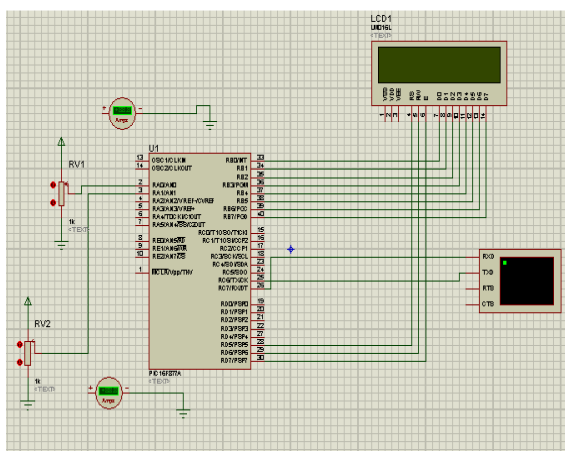

Fig-3. Simulation result of the system

Fig.3 shows the simulation result of the system. The sensor values are captured and digitized as per required ADC rate. Here the system is interfaced with the LED for displaying the measured values of the system. In place of GSM, a virtual terminal is been interfaced for simulation purposes.

5. HARDWARE MODULE

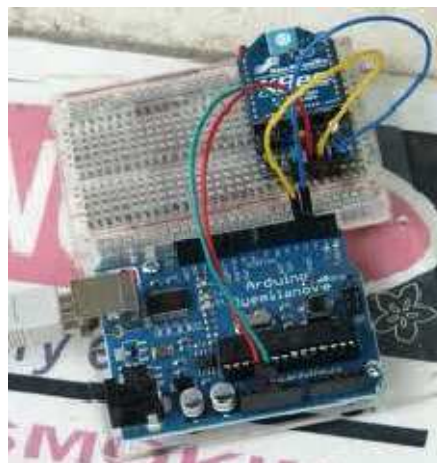

Fig-4. Hardware components of system

The environment parameters are measured using aforementioned transducers and processed using PIC controller. The size of the system can be further reduced in future up-gradations.

6. CONCLUSION

Thus the several parameters like gas level and purity of water level are monitored continuously and when the standard level exceeds a message is sent to the owner as a warning and even in the case of failure in the measure taken a message is sent to the pollution control board. Thus the environment is saved from several hazards of pollution.

REFERENCES

- [1] B. V. D. Zwaan and R. Gerlagh, "Economics of geological CO₂ storage and leakage," *Climatic Change*, vol. 93, pp. 285–309, Mar. 2009.
- [2] M. Argany, M. A. Mostafavi, F. Karimipour, and C. Gagne, "A GISbased wireless sensor network coverage estimation and optimization: A Voronoi approach," in *Transactions on Computational Science XIV*, vol. 6970. New York: Springer-Verlag, 2011, pp. 151–172.
- [3] S. M. Klara, R. D. Srivastava, and H. G. McIlvried, "Integrated collaborativetechnology development program for CO₂ sequestration ingeologic formations–United States Department of Energy R&D", *Energy Convers. Manage.* vol. 44, no. 17, pp. 2699–2712, 2003.
- [4] S. Solomon, "Carbon dioxide storage: Geological security and environmental issues-case study on the Sleipner gas field in Norway," Bellona, Tech. Rep. 1-2007, 2007, pp. 4–5.
- [5] I. Brevik, Q. Eiken, R. J. Arts, E. Lindeberg, and E. Causse, "Expectationsand results from the seismic monitoring of CO₂ injection intoa marine aquifer," in *Proc. 62nd EAGE Conf.*, Glasgow, U.K., 2000,no. B-21.
- [6] D. G. Jones, T. R. Lister, D. J. Smith, J. M. West, P. Coombs, A. Gadalia, M. Brach, A. Annunziatellis, and S. Lombardi, "In Salah gas CO₂storage JIP: Surface gas and biological monitoring," *Energy Procedia*, vol. 4, pp. 3566–3573, Dec. 2011.
- [7] Y. J. Jung, Y. K. Lee, D. G. Lee, K. H. Ryu, and S. Nittel, "Air pollution monitoring system based on geosensor network," in *Proc. IEEE Int.Geosci. Remote Sensing Symp.* vol. 3. Dec. 2008, pp. 1370–1373.

BIOGRAPHIES



K.Gokulram: He is Born At Erode. He Completed Bachelor Of Engineering (Electronics And Communication Engineering) In Karpagam College Of Engineering, Coimbatore, Tamilnadhu, India. Currently Doing Master Of Engineering (Embedded Systems) In Kumaraguru College Of Technology. He presented a paper on national conference at roever college of engineering about solar desalination technique and selected as best paper. His Area of Interest in Microcontroller and Embedded Processors.



T.Dhakshinamoorthy received the Bachelor's degree in Electrical and Electronics from Thanthai Periyar Govt. Institute of Technology, Vellore, Tamilnadu, India. He received master degree in Embedded System from CEG, Anna university, Chennai. He received the Master of Science from The University of Toledo, Ohio, USA and his Research Interest RF/Microwave and Photonics, Ohio, USA And His Research Interest: RF/Microwave And Photonics.