

COMPARISON OF VARIOUS NOISE MITIGATION TECHNIQUE USED WITH CLIPPING FOR REDUCTION OF PAPR IN OFDM

Hemant Choubey¹, Aparna Singh², Amit Shukla³

^{1,3}Student, ²Asst Professor, Electronics and Communication, UIT, M.P, India
hemantchoubey271986@gmail.com, aparna.kushwah@gmail.com, amit.rgi@gmail.com

Abstract

A simple technique used to reduce the PAPR of OFDM signals is to clip the signal to a maximum allowed value, at the cost of BER degradation and out-of-band radiation. Clipping does not add extra information to the signal and high peaks occur with low probability so the signal is seldom distorted. Out-of-band radiation can be reduced by filtering at the transmitter, the filter used in this project consists on a FFT-IFFT pair which is easier to implement than traditional FIR filters and allows the implementation of the clip & filter set several times in order to reduce the peak re growth that filtering introduces. The BER degradation can be mitigated by reconstructing the signal at the receiver. We analyzed the performance of the decision-aided reconstruction (DAR) and improved DAR (IDAR) techniques that iteratively try to guess the original symbols and proposed an improvement for one of those techniques.

Index Terms: Complementary cumulative distribution function (CCDF), high power amplifier (HPA), Orthogonal Frequency Division Multiplexing (OFDM), Peak-to-Average Power Ratio (PAPR), inter-symbol interference (ISI)

1. INTRODUCTION

Introducing a filter after the clipping operation helps mitigating the out-of-band radiation introduced by clipping. Filtering, however, distorts also the signal and causes peak regrowth [6]. A common filter used for this purpose is the FIR filter. In this application the filter used is the FFT-IFFT filter proposed by Armstrong in [1]. This filter achieves better performance than the FIR filter, it introduces less noise into the signal, causes less peak regrowth and needs less computation; since it operates symbol by symbol it causes no inter-symbol interference. Clipping too large peaks is a simple solution to the PAPR problem. Clipping belongs to the group of techniques that reduce large peaks by nonlinearly distorting the signal [8]. It does not add extra information to the signal and too large peaks occur with low probability so the signal is seldom distorted. The maximum peak power allowed is determined by the system specifications, usually by the linear region of the power amplifier. A maximum peak amplitude A is chosen so that the OFDM signal does not exceed the limits of this region, symbols that exceed this maximum amplitude, will be clipped. The clipping function is performed in digital time domain, before the D/A conversion as shown in Figure 1 and the process is described by the following expression

$$x_k^c = \begin{cases} x_k & |x_k| \leq A \\ Ae^{j\phi(x_k)}, & |x_k| > A \end{cases} \quad 0 \leq k \leq N-1 \quad (1)$$

Where x_{ck} is the clipped signal, x_k is the transmitted signal, A is the clipping amplitude and $f(x_k)$ is the phase of the transmitted signal x_k . The graphical expression of this function is shown in Figure 2. The clipping ratio (CR) is defined as

$$C.R = \frac{A}{\sigma} \quad (2)$$

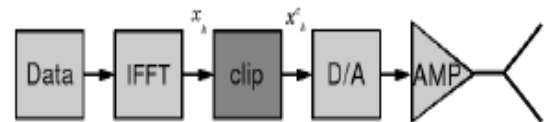

Fig1.Clipping in the transmitter

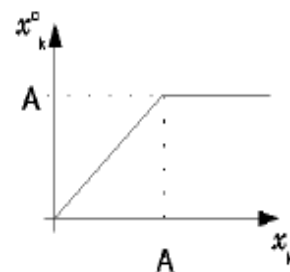

Fig2.Clipping Function

If the CR is too low (this depends on the modulation), the performance of DAR is degraded because false detection increases.

3.2 Improved Decision-Aided Reconstruction (IDAR)

Method

The DAR method was proposed to mitigate the clipping noise but it does not deal with the intermodulation noise. The intermodulation products are reduced by setting the IBO of the power amplifier at the linear region; however, in order to maximize the power efficiency of the amplifier, the IBO is set nearly at the saturation region degrading this way the BER due to the high non-linearity. The improved DAR method mitigates both the clipping noise and the inter-modulation noise. The IDAR method [2], like the DAR one, is an iterative method applied at the receiver and was proposed by Boonsrimuang et al. in [2], Figure 6 shows the block diagram. It repeats at the receiver the clipping and the amplifying operations, so the receiver needs to know the clipping amplitude A and the amplifier characteristics. In Figure 6 can be seen that the method starts by estimating the original signal like in the DAR method

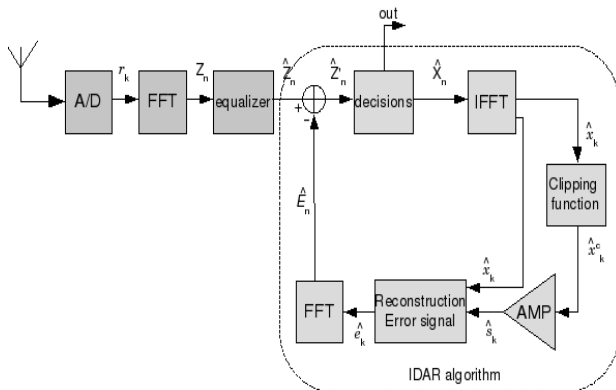

Fig6. IDAR algorithm block diagram

By using this method the intermodulation noise is mitigated, relatively even when the nonlinear amplifier is operated at the saturation region, while with DAR the BER is severely affected by this noise. Although the method shows a good performance for different required signal to noise ratios, for CR lower than 3 dB around 0 dB.

3.3 IDAR Including the FFT-IFFT Filter (IDARF)

The IDAR method shows a very good performance by mitigating the clipping and the intermodulation noises. However, in order to reduce the out-of-band radiation it is advisable to use a filter in the transmitter; in this case the filter used is the FFT-IFFT filter. So, if the clipping operation is followed by the filter at the transmitter, this filter should also

be included in the IDAR method at the receiver, Figure7 shows a block diagram of the new method. In order to include the FFT filter in the IDARF method, the same number of zeros as in the transmitter are inserted into the estimated signal before converting it to time domain. Clip & filter is applied to the time domain signal which is then amplified like in the IDAR method. The zeros are removed from the signal after the amplifier; the signal is transformed to frequency domain, the zeros are removed and the signal is transformed back to time domain in order to calculate the error signal. The error signal is the difference between the estimated signal \hat{x}_k (before adding the zeros) and the signal that suffered the clip&filter and amplifying process, s_k , after removing the zeros. The red boxes in Figure7 show the operations that have to be added to the IDAR algorithm in order to include the FFT filter in the method.

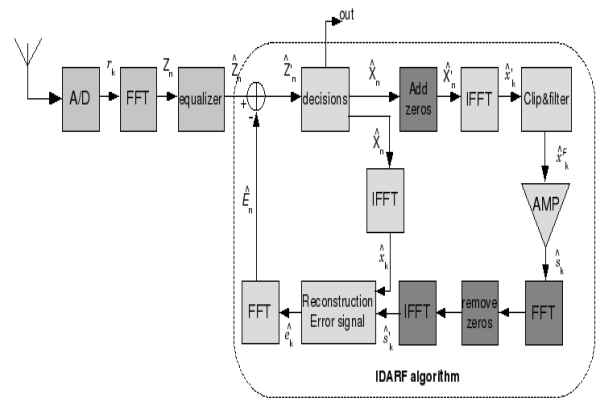

Fig7. IDARF algorithm block diagram

4. SIMULATION RESULTS

After theoretically studying noise mitigation techniques, these techniques have been tested both in a flat fading channel and in a selective fading channel. The simulations have been made for the 16-QAM and the 64-QAM modulations and all them use 256 subcarriers, when analyzing the system for different CR, the SNR used varies depending on the modulation, this information is available in Table 3. The frequency selective channel parameters are shown in Table 1 and the number of iterations used for each method is shown in Table 2.

Table 1: Channel parameters

tap	delay	tap coeff
h0	0.0	0.8405
h1	0.3	0.4726
h2	1.0	0.2658

Table 2: number of iterations

tap	delay
clip&filter	1
DAR	2
IDAR	2
IDARF	2

Table 3: system parameters

number of subcarriers	256
CR	4dB
SNR 16QAM	15dB
SNR 64QAM	20dB

4.1 Flat Fading Channel

This section shows the performance of the BER of OFDM signals modulated with 16 and 64QAM and in a flat fading channel when varying the SNR and the CR. Figures 8, 9 and 10 show the BER performance of a 16QAM modulation when varying the SNR from 0 to 18 dB. The simulations in Figure 8 show the performance of the DAR and IDAR methods when no filter is applied at the transmitter. The results show that the BER performance for DAR and for IDAR is very similar, being IDAR slightly better. When the FFT filter is used at the transmitter, IDARF shows clearly better performance than DAR and IDAR. Figure 10 shows that IDARF is also better than IDAR without filter at the transmitter, keeping the BER very close to that of the no clipping case.

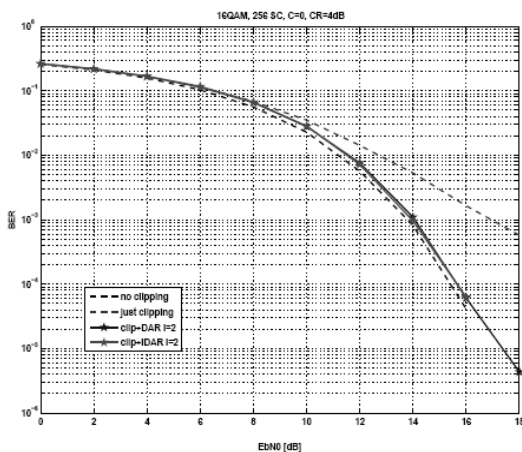

Fig 8: DAR and IDAR methods with no filter in the transmitter, 16QAM modulation in flat fading channel, CR=4 dB, N=256 subcarriers

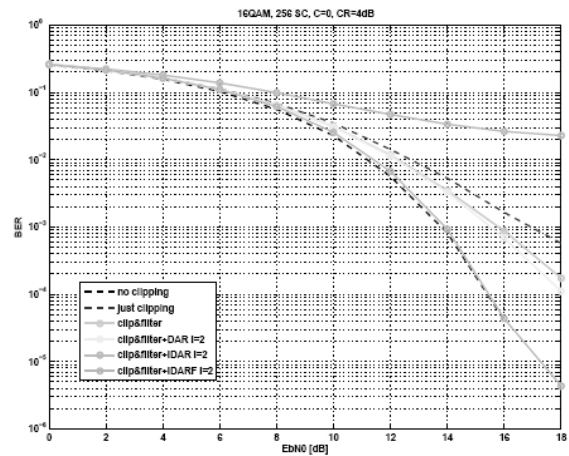

Fig 9: IDARF, DAR and IDAR methods with filter in the transmitter, 16QAM modulation in flat fading channel, CR=4 dB, N=256 subcarriers

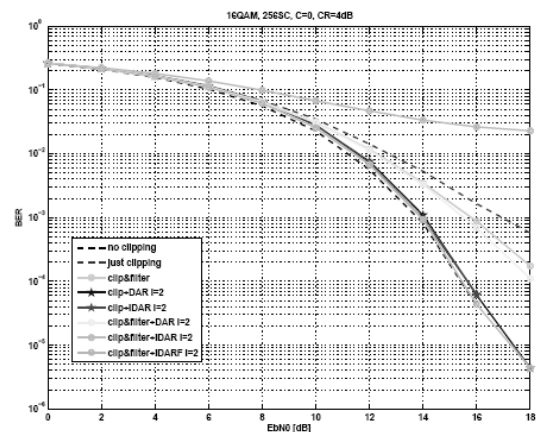

Fig 10: DAR, IDAR and IDARF methods with and without filter in the transmitter, 16QAM modulation in flat fading channel, CR=4 dB, N=256 subcarriers

Figures 11, 12 and 13 show the same simulations as the previous figures but this time holding the SNR at 15 dB and varying the CR from 2 to 14 dB. For CR > 4 dB, the performance of DAR and IDAR in Figure 11, when no filter is applied, is approximately the same, for CR < 4 dB performs better than DAR. When the filter is applied, Figure 12, and for CR < 8 dB approximately, IDARF provides a significant better performance than DAR or IDAR and DAR provides no improvement compared to just clip&filter, also the difference between IDARF and DAR or IDAR without filter in the transmitter is very small, see Figure 13. As the CR decreases, the performance of all methods degrades, being DAR without filtering at the transmitter the one that faster degrades. From a

CR of 8 dB the performance of all methods becomes flat and similar for all them.

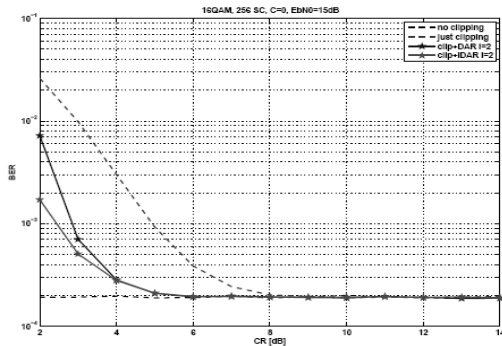

Fig11: DAR and IDAR methods with no filter in the transmitter, 16QAM modulation in flat fading channel, SNR=15 dB, N=256 subcarriers

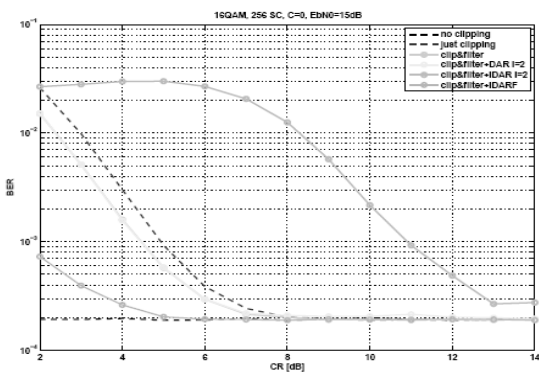

Fig 12: IDARF, DAR and IDAR methods with filter in the transmitter, 16QAM modulation in flat fading channel, SNR=15 dB, N=256 subcarriers

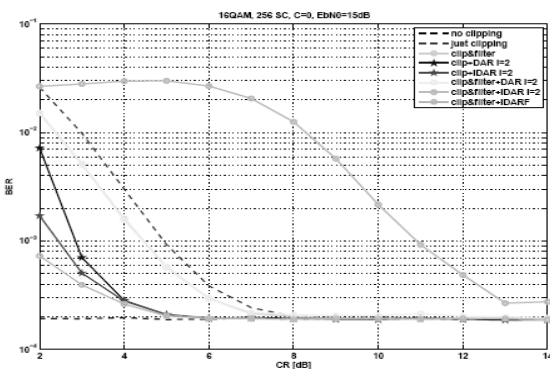

Fig13: DAR, IDAR and IDARF methods with and without filter in the transmitter, 16QAM modulation in flat fading channel, SNR=15 dB, N=256 subcarriers

Figures 14, 15 and 16 show the BER performance of a 64QAM modulation when varying the SNR from 0 to 30 dB and for a clipping ratio of 4 dB. In Figure 4.7, when no filter is applied at the transmitter, the IDAR method performs clearly better than DAR for SNR > 12 dB approximately, for lower SNR their performance is nearly the same. For an SNR < 20 dB they behave like when no clipping is applied and after that they behave like when just clipping is applied. When the filter is used in the transmitter, Figure 4.8, the performance of IDARF for the whole SNR range is very close to that when no clipping is applied, on the other hand, there is nearly no difference between using IDAR and using just clip&filter. When comparing all methods in Figure 4.9, IDARF performs clearly better than DAR and IDAR without filter in the transmitter.

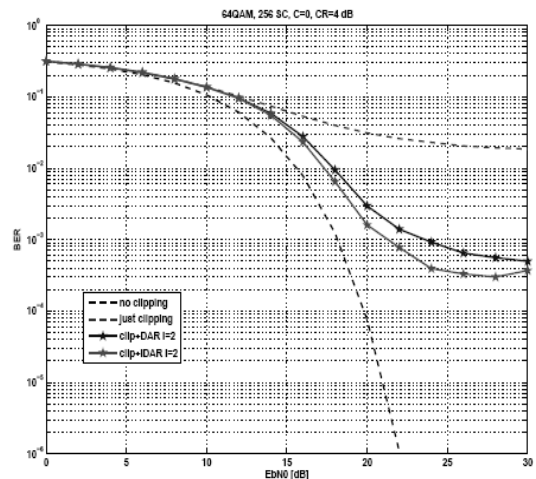

Fig 14: DAR and IDAR methods with no filter in the transmitter, 64QAM modulation in flat fading channel, CR=4 dB, N=256 subcarriers

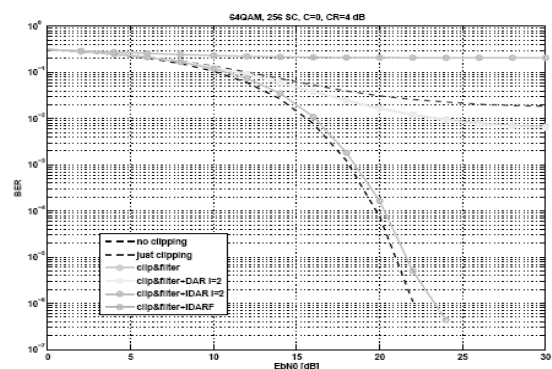

Fig 15: IDARF, DAR and IDAR methods with filter in the transmitter, 64QAM modulation in flat fading channel, CR=4 dB, N=256 subcarriers

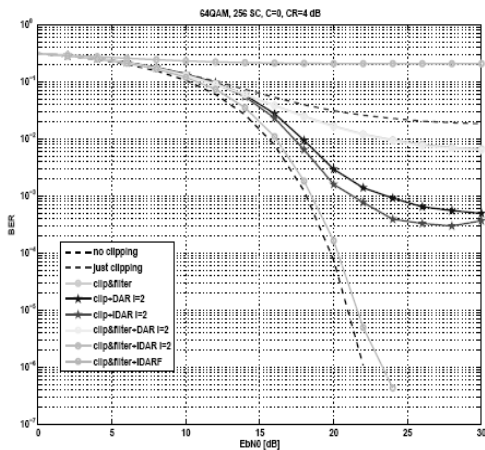

Fig 16: DAR, IDAR and IDARF methods with and without filter in the transmitter, 64QAM modulation in flat fading channel, CR=4 dB, N=256 subcarriers

Figures 17, 18 and 19 show how those methods behave when holding the SNR at 20 dB and varying the CR from 2 to 14 dB. Without filter in the transmitter, Figure 17, IDAR performs slightly better than DAR for CR < 5 dB, after that the performance is approximately the same. With filter in the transmitter, 18, IDARF performs much better than the other methods for CR < 9 dB and using DAR yields the same results as just clip&filter. Regarding the whole set of methods, Figure 19, IDARF performs better than IDAR and DAR for CR < 6 dB.

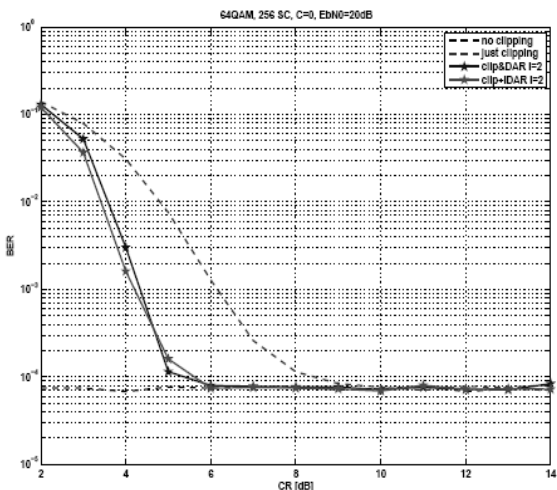

Fig 17: DAR and IDAR methods with no filter in the transmitter, 64QAM modulation in flat fading channel, SNR=20dB, N=256 subcarriers

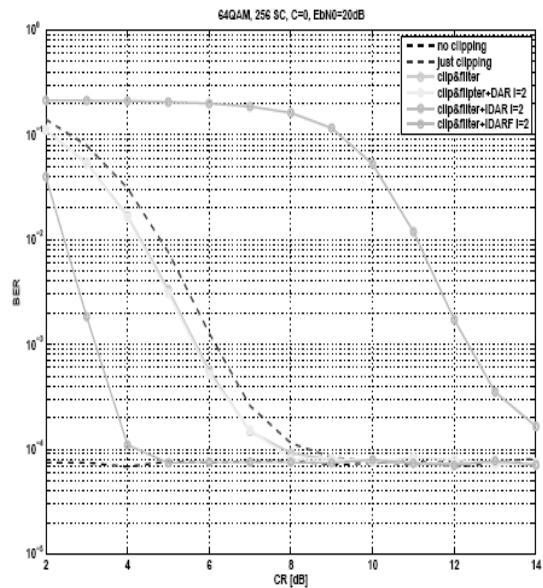

Fig 18: IDARF, DAR and IDAR methods with filter in the transmitter, 64QAM modulation in flat fading channel

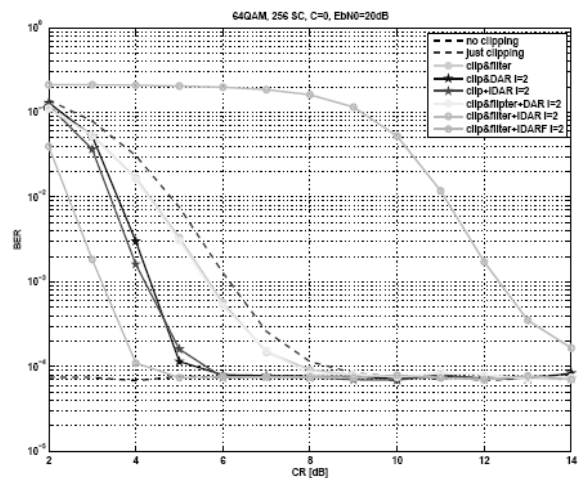

Fig 19: DAR, IDAR and IDARF methods with and without filter in the transmitter, 64QAM modulation in flat fading channel, SNR=20 dB, N=256 subcarriers

CONCLUSIONS

When using the 16QAM modulation, DAR and IDAR have similar performance when no filter is applied at the transmitter, this performance is also very similar to that of IDARF when the FFT filter is applied at the transmitter, although IDARF performs slightly better. When the modulation used is 64QAM, IDAR performs better than DAR without filter at the transmitter and they both have similar

behavior. IDARF, on the other hand, performs clearly better than DAR and IDAR and its behavior is closer to the case when no clipping is applied than to IDAR and DAR. When the methods are analyzed for different clipping ratios, the simulations show that when the filter is used in the transmitter and for $CR < 7$ dB, IDARF performs better than all the other methods, for higher CR they all perform the same. When comparing all methods without filter in the receiver, IDARF performs better than IDAR and DAR for $CR < 4$ dB, for higher CR their performances are very similar. The filter is an important element in OFDM systems since it reduces the out-of-band radiation and ICI caused by clipping. As seen in the simulations, when the filter is used in the transmitter, the method that better performs in the receiver is IDARF. Therefore, when clipping is applied, the better solution in order to mitigate the noise that it introduces is to use the FFT filter together with the IDARF method.

REFERENCES

- [1] Jean Armstrong. "New OFDM Peak-to-average Reduction Scheme". In IEEE Vehicular Technology Conference, Rhodes, Greece, 2001
- [2] Pisit Boonsrimuang, Kazuo Mori, Tawil Paungma, and Hideo Kobayashi. "Proposal of Clipping and Inter-modulation Noise Mitigation Method for OFDM Signal in Non-linear Channel". IEICE Trans. Commun., 2005.
- [3]Khaled Fazel and Stefan Kaiser. Multi-Carrier and Spread Spectrum Systems. Wiley,2003.
- [4]Hiroshi Harada and Ramjee Prasad. Simulation and Software Radio for Mobile Communications.Artech House, 2003.
- [5]Dukhyun Kim and Gordon L. Stuber. "Clipping Noise Mitigation for OFDMby Decisionaided Reconstruction". IEEE Communication Letters, 1999.
- [6]Xiaodong Li and Leonard J. Cimini. "Effects of Clipping and Filtering on the Performance of OFDM". IEEE Communication Letters, 1998
- [7]Ye (Geoffrey) Li and Gordon L. Stuber. Orthogonal Frequency Division Multiplexing for Wireless Communications. Springer, 2006.
- [8]Ramjee Prasad. OFDM for Wireless Communication Systems. Artech House, 2004
- [9]Henrik Schulze and Christian Luders. Theory and Applications of OFDM and CDMA. Wideband Wireless Communications. Wiley, 2003
- [10]H. Sizon. Radio Wave Propagation for Telecommunication Applications. Springer,2003

BIOGRAPHIES



Hemant Choubey, he has received the B.E. degree in Electronics and communication engineering from Rajiv Gandhi Technical University Bhopal, in 2009. He is currently pursuing M.E degree in Digital Communication from RGTU Bhopal.