

MODELING AND SIMULATION OF SOLAR PHOTOVOLTAIC MODULE USING MATLAB / SIMULINK

Jay Patel¹, Gaurag Sharma²

¹ PG Student, ² Assistant professor Electrical department, Birla Vishvakarma Mahavidhyalaya, Gujarat, India, jaypatel151188@gmail.com, gksharma@bvmengineering.ac.in

Abstract

The paper presents the modeling, simulation and implementation of the solar photovoltaic cell using MATLAB/SIMULINK. The I-V, P-V & I-V characteristics are obtained for (1) Single solar cell module (2) Solar PV module with variable temp. & fixed radiation (3) Solar PV module with fixed temp. & variable radiation with M.file and mathematical model using MATLAB/SIMULINK.

Index Terms: photovoltaic module, radiation, temperature, M.file, MATLAB/SIMULINK

1. INTRODUCTION

One of the major concerns in the power sector is the day-to-day increasing power demand but the unavailability of enough resources to meet the power demand using the conventional energy sources. Energy is the prime mover of economic growth and is vital to the sustenance of a modern economy. Future economic growth crucially depends on the long-term availability of energy from sources that are affordable, accessible and environment. Demand has increased for renewable sources of energy to be utilized along with conventional systems to meet the energy demand. Renewable sources like wind energy and solar energy are the prime energy sources which are being utilized in this regard. The continuous use of fossil fuels has caused the fossil fuel deposit to be reduced and has drastically affected the environment depleting the biosphere and cumulatively adding to global warming. Solar energy is abundantly available that has made it possible to harvest it and utilize it properly. Solar energy can be a standalone generating unit or can be a grid connected generating unit depending on the availability of a grid nearby. Thus it can be used to power rural areas where the availability of grids is very low. Another advantage of using solar energy is the portable operation whenever wherever necessary. In order to tackle the present energy crisis one has to develop an efficient manner in which power has to be extracted from the incoming solar radiation. The power conversion mechanisms have been greatly reduced in size in the past few years. The development in power electronics and material science has helped engineers to come up very small but powerful systems to withstand the high power demand. they can hardly compete in the competitive markets as a prime power generation source. The PV module represents the fundamental power conversion unit of PV generator system. The output characteristics of PV module depends on the solar radiation, the cell temperature and output voltage of PV module.

2. PV MODULE

A solar cell is the building block of a solar panel. A photovoltaic module is formed by connecting many solar cells in series and parallel. Considering only a single solar cell; it can be modeled by utilizing a current source, a diode and two resistors. This model is known as a single diode model of solar cell. Two diode models are also available but only single diode model is considered here in fig. 1

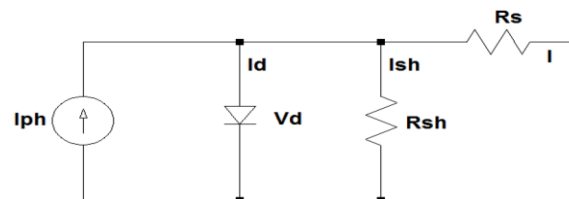

Fig. 1 Equivalent circuit model of PV cell

The characteristic equation for a photovoltaic cell is given by

$$I_o = (N_p * I_{ph}) - (N_p * I_{rs}) * (\exp((q/(k*T*A)) * (V_o / N_s)) - 1) \quad (1)$$

Where

$$I_{ph} = (I_{scr} + k_i * (T - T_r)) * (s/100); \quad (2)$$

$$I_{rs} = I_{rr} * ((T/T_r)^3) * \exp(q * E_g / (k * A)) * ((1/T_r) - (1/T)) \quad (3)$$

$$T_r = (T_r1 - 32) + 273 \quad (4)$$

I_o & V_o : Cell output current and voltage;
 I_{rs} : Cell reverse saturation current;
 T : Cell temperature in Celsius;
 k : Boltzmann's constant : $1.38 * 10^{-19}$ J/K;
 q : Electron charge: $1.6 * 10^{-23}$ C;

K_i : Short circuit current temperature coefficient at I_{sc} ;
 S : Solar radiation ;
 I_{sc} : Short circuit current at 25 degree Celsius;
 I_{ph} : Light-generated current;
 E_g : Band gap for silicon;
 T_r : Reference temperature;
 R_{sh} : Shunt resistance;
 R_s : Series resistance;

A PV array is a group of several PV cells which are electrically connected in series and parallel circuits to generate the required current and voltage. The equivalent circuit for the solar module arrange in N_p parallel and N_s series cells is shown in fig. 2

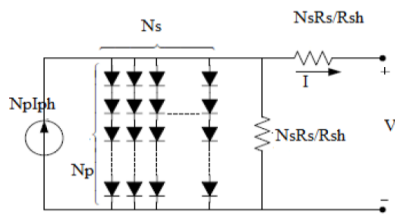

Fig.2 Equivalent circuit of solar array

The shunt resistance R_{sh} is inversely related with shunt leakage current to the ground .In general , the PV efficiency is insensitive to variation in R_{sh} and the shunt -leakage resistance can be assumed to approach infinity without leakage current to ground . on the other hand ,a small variation in R_s will significantly affect the PV output power .

3. IMPLEMENTATION AND SIMULATION OF MODEL

1) The proposed model of single solar photovoltaic cell is implemented and shown in fig. 3 and fig. 4

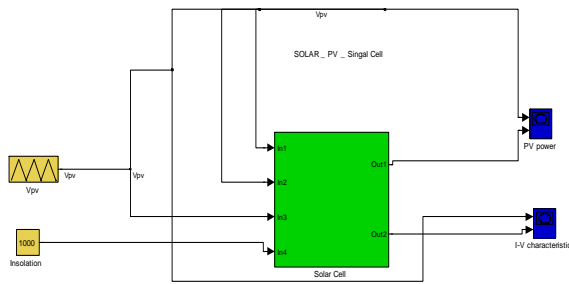

Fig. 3 Masked single photovoltaic cell model

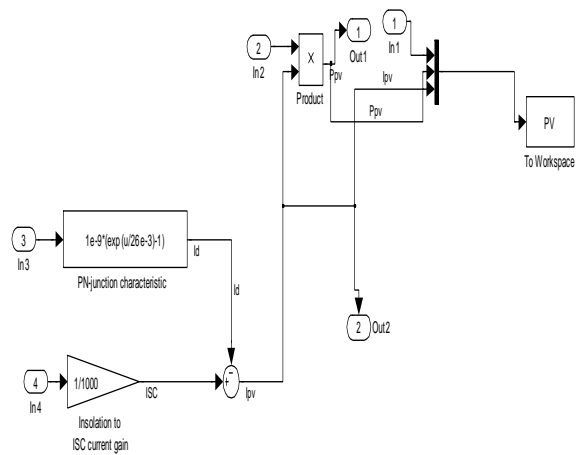

Fig. 4 Subsystem of single photovoltaic cell model

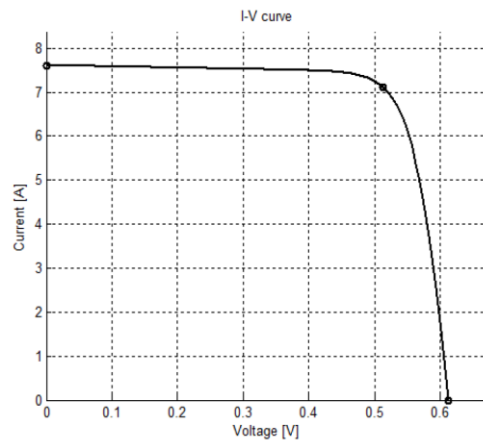

Fig.5 I-V characteristics of single solar cell

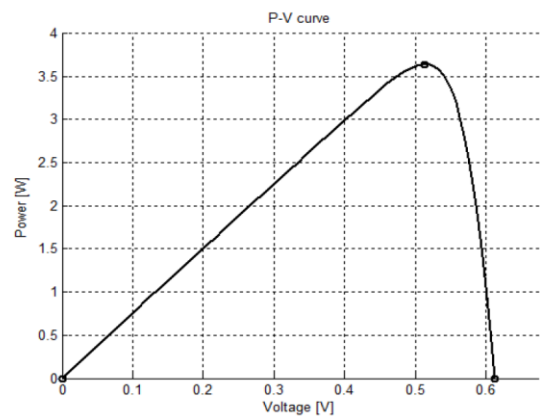

Fig.6 P-V characteristics of single solar cell

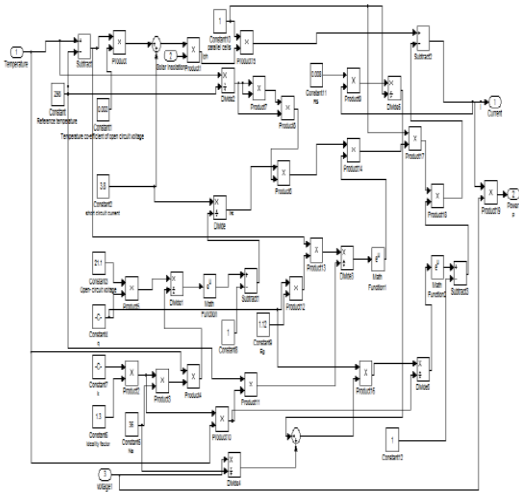

Fig. 7 MATLAB simulation of PV module

2) Output of Solar PV Array with variable Temp. & Fixed Radiation using M.file and matlab modeling

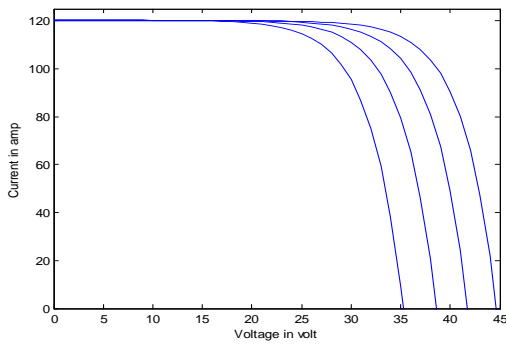

Fig. 8 I-V characteristics of solar cell with variable Temp. & Fixed Radiation

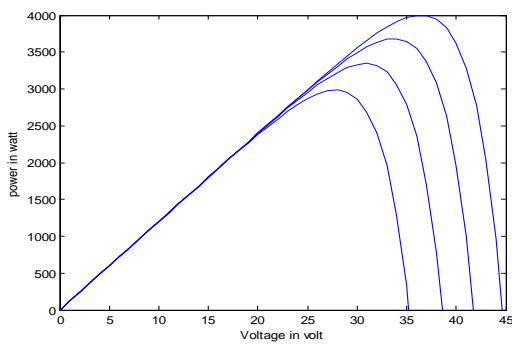

Fig. 9 P-V characteristics of solar cell with variable Temp. & Fixed Radiation

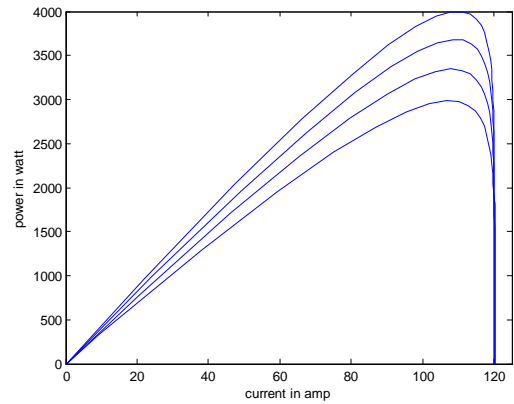

Fig. 10 P-I characteristics of solar cell with variable Temp. & Fixed Radiation

3) Output of Solar PV Array with Fixed Temp. & variable Radiation using M.file and matlab modeling

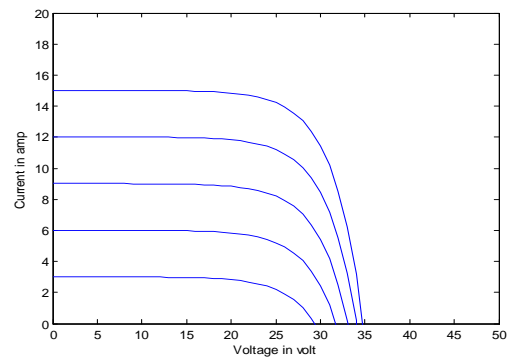

Fig. 11 I-V characteristics of solar cell with Fixed Temp. & variable Radiation

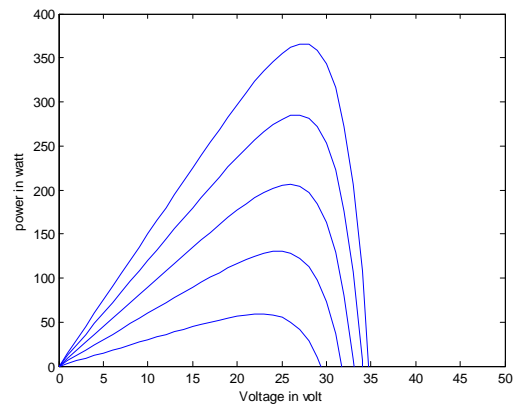

Fig. 12 P-V characteristics of solar cell with Fixed Temp. & variable Radiation

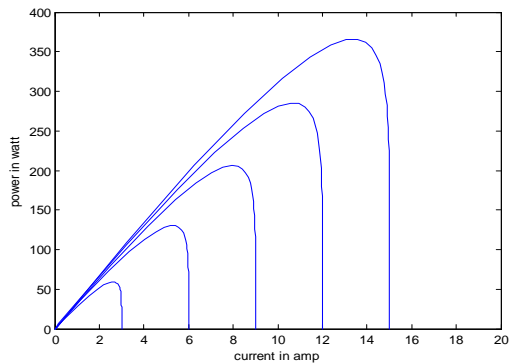

Fig. 13 P-I characteristics of solar cell with Fixed Temp. & variable Radiation

CONCLUSIONS

The proposed model and using m.file of PV module takes solar radiation intensity and cell temperature as input and outputs the I-V and P-V characteristics under various conditions. we conclude that The insolation change affects the photon generated current and has very little effect on the open circuit voltage and we also simulate and modeling of solar cell and measure the different characteristics. and also measure the effect of variation in temperature that if the temperature increases the solar cell efficiency is reduced. As we increase the solar radiation, higher would be the solar input to the solar cell and hence power magnitude would increase for the same voltage value. With increase in the solar radiation the open circuit voltage increases. This model can be used for the analysis in the field of solar photovoltaic system and MPPT technologies .

ACKNOWLEDGEMENTS

The authors would like to thank Dr.. B.R Parekh and prof. N.G misra of Birla Vishavakarma Mahavidhyalaya Engineering College,v.v nagar ,Gujarat,India contribution to this paper.

REFERENCES:

- [1] John A. Duffie & William A. Beckman, "Solar Engineering of Thermal Process", 3rd ed, John Wiley & Sons, pp. 747-773, (2006).
- [2] Nicola M. Pearsall and Robert Hill, "Clean electricity from photovoltaic", 3rd ed., World Scientific, pp. 671-712, (2004)
- [3] R. Messenger and J. Ventre, Photovoltaic Systems Engineering, CRC Press, 2000, pp.41-51.
- [4] S. W. Angrist, , Direct Energy Conversion, Allyn and Bacon, Inc., 4th edition, 1982, pp. 177-227.
- [5] O. Wasynczuk, "Dynamic behavior of a class of photovoltaic power systems," IEEE Transactions on Power Apparatus and Systems, vol. PAS-102, no. 9, 1983, pp. 3031-3037.

- [6] I. S. Kim and M. J. Youn, "Variable-structure observer for solar array current estimation in a photovoltaic power-generation system," IEE Proceedings-Electric Power Applications, , vol. 152, no. 4, 2005, pp. 953959.

BIOGRAPHIES:



Jay Patel received the B.E(Electrical Engineering) degree from Sardar Patel University (Birla Vishvakarma Mahavidhyalaya Engineering College) in 2010. he is currently a M.E (power system) student (3rd semester) In Birla Vishvakarma Mahavidhyalaya Engineering College from Gujarat Technological University. His current

research interests include solar enregy and power system protection



Gaurang K.Sharma is Presently working in Electrical Engineering Dept .B.V.M Engineering College ,previously worked with ERDA –Baroda having total 12 years experience in Multinational Industries as well as Academic Institutions.